



**QUICK
START
MANUAL
FOR
GATEWAY**

Preliminary

Thank you for purchasing Gateway product from **Renu Electronics Pvt. Ltd.** Gateway Product is versatile protocol converter / Data sharer with Windows based configuration Software.

This manual will help you to **safely** install, configure and operate Gateway Products.

All the safety warnings and precautions must be followed to ensure proper unit performance and personal safety.

Warnings used in this manual:

DANGER



Danger Warnings are used to indicate situations, locations and conditions that can cause serious injury or death.

CAUTION



Caution Warnings are used to indicate situations and conditions that can cause operator injury and/or unit damage

IMPORTANT

Gateway Series Products are intended to be protocol converters / Data sharer device, to work with PLCs, Inverters or any device having serial port with any protocol. Which actually allows sharing data between different devices with different or similar communication protocols. Also it can take control actions on request of device being connected. It is assumed that the user is well acquainted with the PLCs / Inverters / Controllers being used.

Any mechanical or electrical modification to this unit will void all warranties.

We hope that you find this manual informative. If additional information or technical assistance is needed please contact:



Renu Electronics Private Limited

'Renu House', Survey No. 2/6,
Near Baner Telephone Exchange
Baner Road, Pune – 411 045
Maharashtra, INDIA

Tel: +91-020-7292840

Fax: +91-020-7292839

E-mail: replengg@vsnl.com

Manual Revisions:

If you contact us in reference to this manual, please include the following revision number

Name: Gateway Operation Manual **Revision:** QMAN\GWY\1001\Rev0

Table of Contents

Preliminary.....	i
Contents.....	ii
1.0 Introduction.....	1-1
1.1 Purpose of this manual.....	1-1
1.2 Introduction to Gateway.....	1-1
1.3 Gateway Specifications.....	1-2
2.0 Hardware.....	2-1
2.1 Mounting.....	2-1
2.2 Power Requirements.....	2-2
2.3 Communication Ports.....	2-3
3.0 Getting Started.....	3-1
3.1 Introduction.....	3-1
3.2 Project – Devices, Reg. Address and Blocks.....	3-1
3.3 Device Communications.....	3-2
4.0 Understanding Gateway Features.....	4-1
4.1 Repeat Cycle	4-1
4.2 Control Word.....	4-3
4.3 Error Indication Bit.....	4-5
4.4 Selectable Baud rate.....	4-7
4.5 LEDs for Communication Status.....	4-8
5.0 Configuration Software.....	5-1
6.0 How Do I Start?.....	6-1

Introduction

In this chapter. . . .

- Purpose of this Manual
- Introduction to Gateway
- Gateway Specification

1.1 Purpose of this Manual

The intention of this Operation Manual is to provide a guide for Safe installation, Configuration and operation of Gateway series models. This manual is applicable to both models one which take power from External Device connected (PLC, Controller etc.) itself through the Communication cable (Gateway-PP) and another which takes power from external source (Gateway-EP).

Read this operation manual thoroughly before installing and operating Gateway.

This document is based on information available at the time of its publication. While efforts have been made to be accurate, the information in this document may not cover all the details or variations in hardware or software. Features described herein may not be present in all hardwares. Renu Electronics reserves the right to update information in this publication without prior notice.

1.2 Introduction to Gateway

Gateway Series protocol converters provide interface between different devices having different or same communication protocol. Gateway communicates with your PLCs / Inverters / Controllers using RS-232 or RS485 serial communication. External +24VDC supply is required for operating Gateway (Gateway-EP). Another models take power from PLC on their PLC port (Gateway-PP).

Configuration of Gateway :

Each Gateway has to be configured using Windows based configuration Software before connecting it to the PLC.

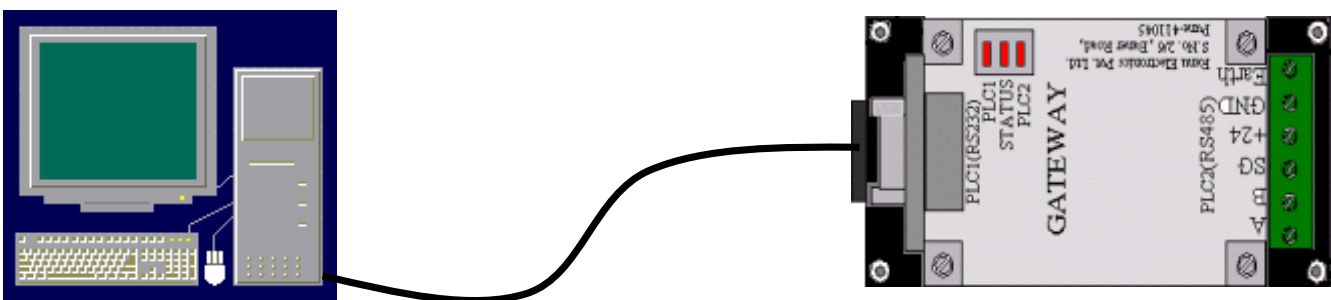

Normal Operation:

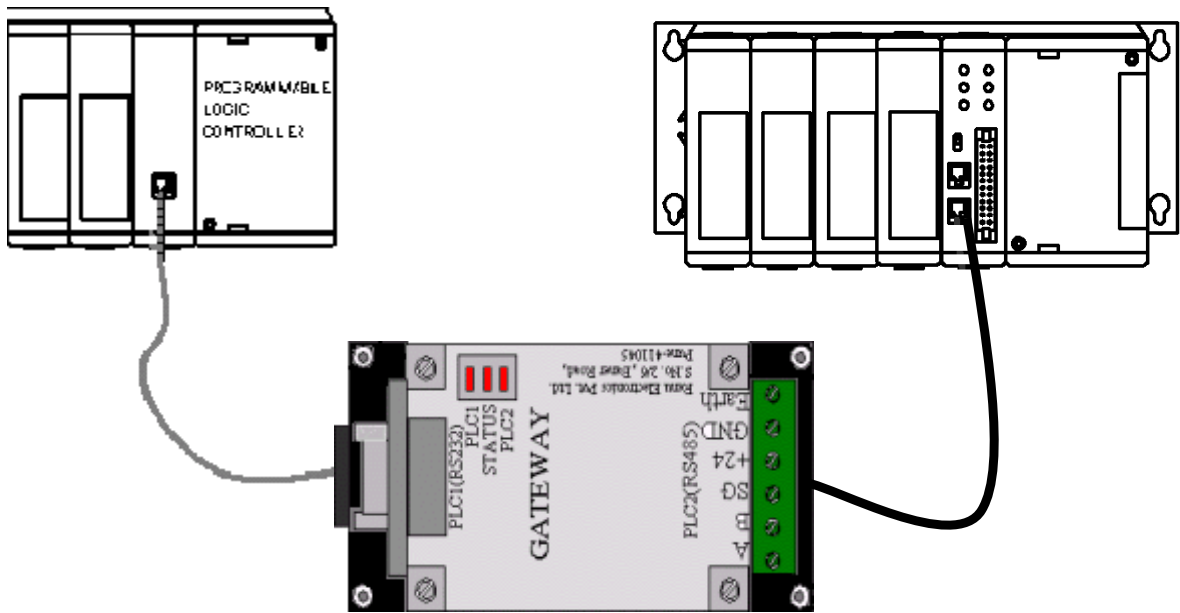

Connect correct Gateway to PLC cables on both communication ports and your Gateway is running.

Application:

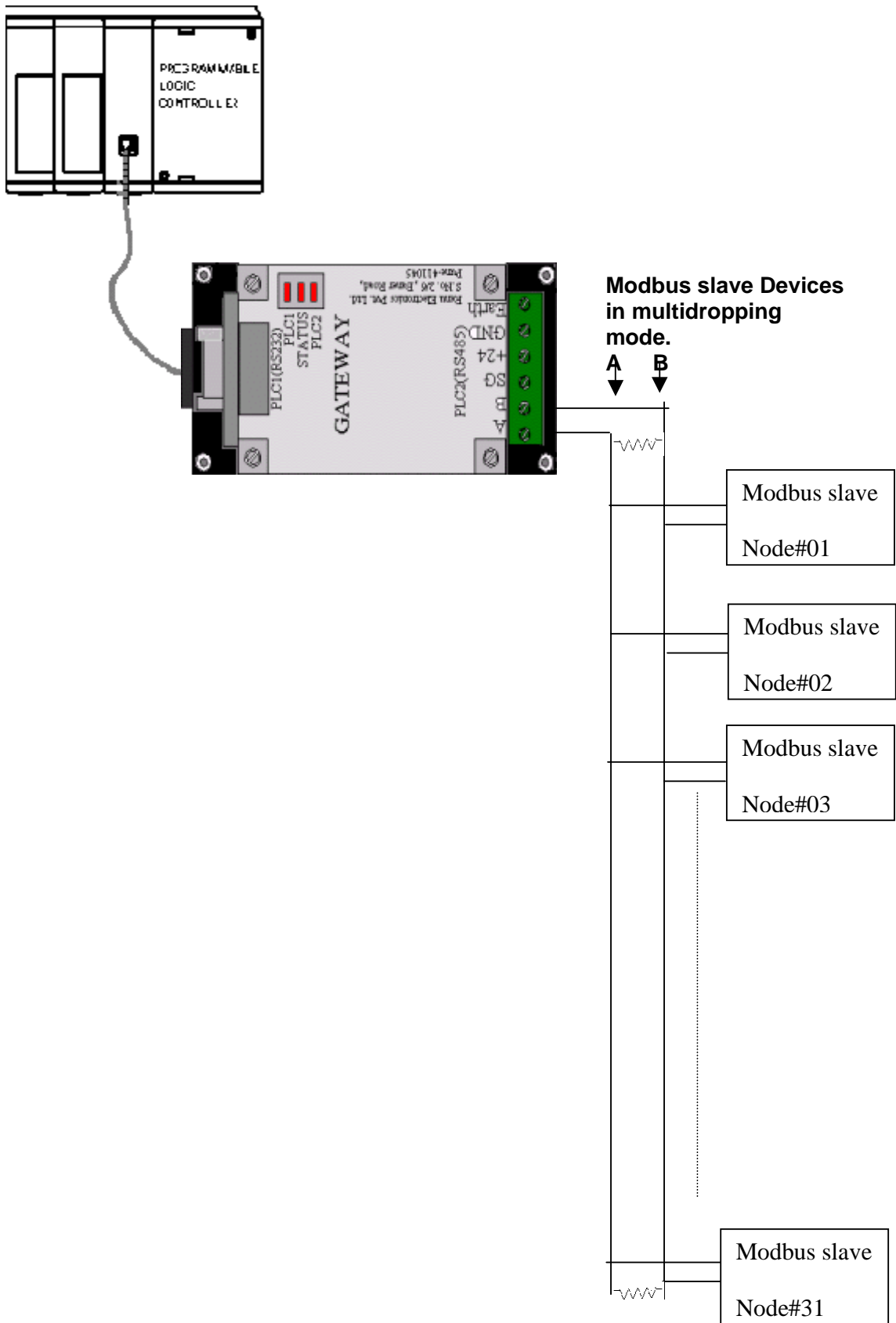

1.3 Gateway Specifications

Power Supply	: 24 VDC +/- 5 % (50 ma MAX.) No Fuse inside. 5 VDC +/- 5 % FROM PLC (75 ma MAX.)
Communication	: Two ports as follows: Com 1: RS 232C For configuration and PLC communication Com 2: RS 485/RS232C (As per order) For PLC communication
Indications	: PLC1 LED STATUS LED PLC2 LED
Temperature	: Operating: 0 to 60 °C Storage: - 40 to 90 °C
Humidity	: 10% to 90% (Non condensing)
Immunity to ESD	: Level 3 as per IEC1000-4-2
Immunity to Transients	: Level 3 as per IEC1000-4-4
Radiated Susceptibility	: Level 3 as per IEC1000-4-3
Emissions	: EN55011 CISPR A
Dimensions	: 97mm(W) X 15.mm (H) X 42mm(D) (DIN RAIL mounting)

Hardware

In This Chapter . . .

- Mounting, Panel Cutouts
- Power Requirements
- Communication ports

2.1 Mounting

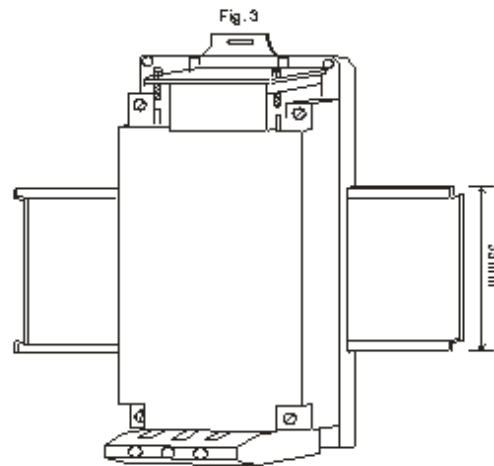
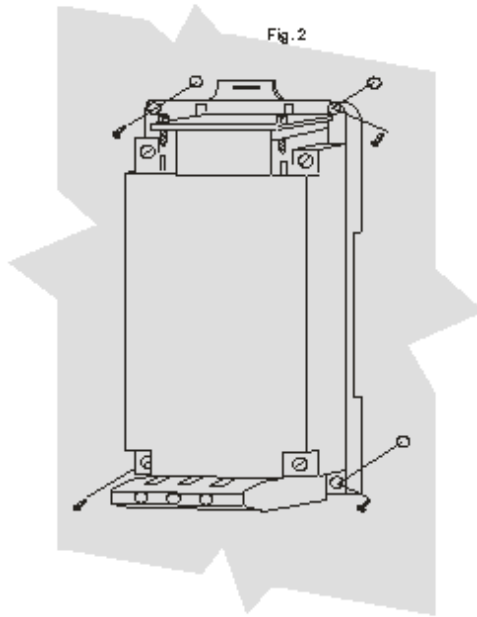
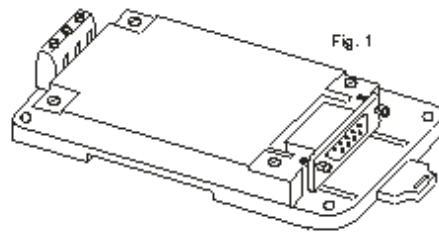

2.2 Power Requirements

Both the Gateway models are DC powered. The specified voltage range for gateway-EP model is +24VDC + 5%. For Gateway-PP models power is supplied from the PLC port cable and the supply voltage range is +5VDC + 5%. Make sure to check PLC power before connecting cable to Gateway-PP models.

Please follow the instructions given below while making power supply connections for Gateway-EP models:

Follow the wiring diagram on the sticker on the unit which shows terminals for the positive DC, negative DC and Earth.

To make a connection strip about 1/4" of insulation of the wire, turn the connector screw counter-clock wise until the gap is wide open. Insert the wire all the way in and turn the screw clockwise until it is tight.

Wire lengths should be minimum. Wires should run in pairs with a neutral or common paired with a live or signal wire.

Please note that, gateway is not Fused internally. Fuse should be connected from outside wherever required.



All the Gateway products are housed in a molded ABS plastic case which eliminates any electrical shock hazard. Hence Safety Earth is not required to be connected to the chassis of the unit.



The DC ground is not directly coupled to Earth ground internally. The unit is designed to operate properly whether or not the DC ground is connected to the Earth ground. We do recommend, however, that if the DC ground has to be connected to the Earth ground, the Earth connection should be made to a central star point as poor site earths can introduce noise into a system.



Do not power Gateway and inductive loads with the same power supply even though there is enough immunity in the Gateway to withstand the transients present on these lines. Avoid using power supplies with large capacitive outputs, which may cause problems if power is cycled within a short time period.



If wiring is to be exposed to lightening or surges, use appropriate surge suppression devices.



Keep AC, high energy and rapidly switching DC wiring separate from signal wires.



Connecting high voltages or AC power mains to the DC input will make Gateway unusable and may create an electrical shock hazard to personnel. Such a failure or shock could result in serious personal injury, loss of life and/or equipment damage. DC voltage sources should provide proper isolation from main AC power and similar hazards.

2.3 Communication ports

Each Gateway unit has two communication ports . Description of each is given in following topics.

- Com port1:
This port is RS232C port and is used for configuration of gateway. Same port can be used for PLC communication after proper configuration.

This port is used to download the firmware, Drivers and / or Project in to the Gateway unit. As the same port is used for PLC communication, when Gateway is communicating with a PC for programming, PLC operations are suspended. Pin description of this Port is given below:

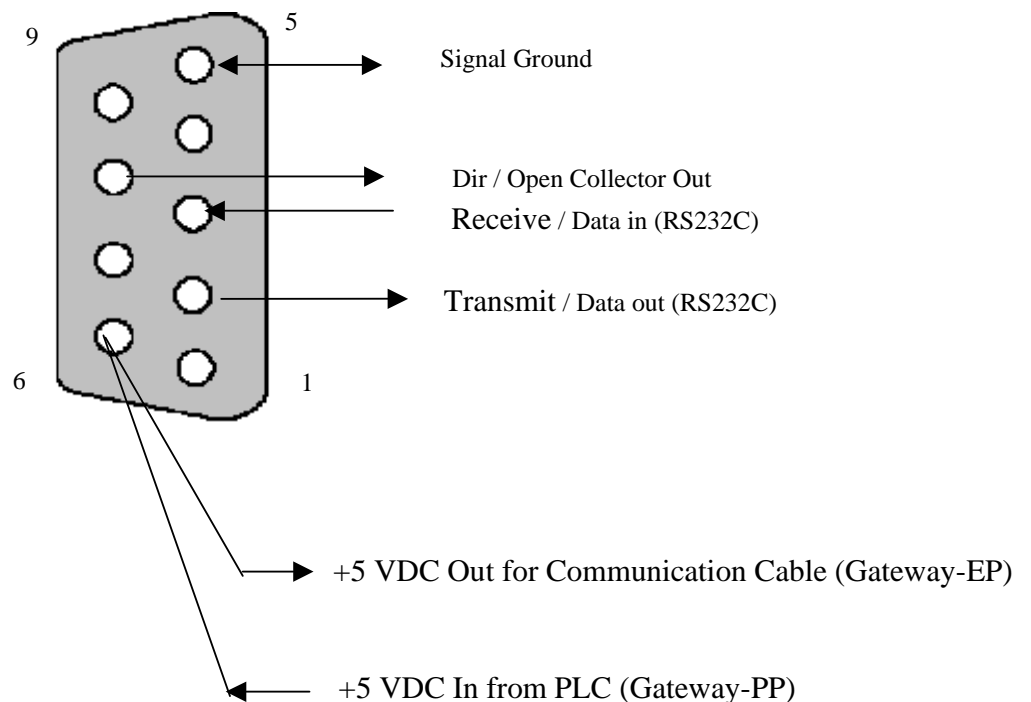

➤ Com port2:

This port is RS232C or RS485 (2 wire) depending upon ordering information and is used for PLC communication.

[I] For Gateway-EP

i) RS232C

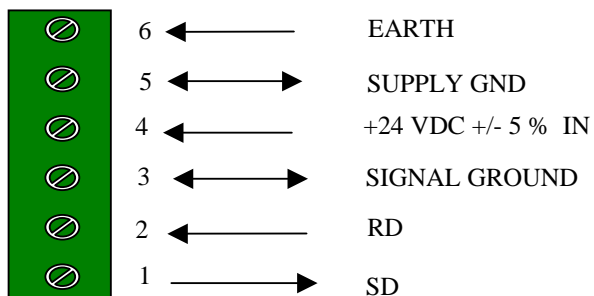

ii) RS485

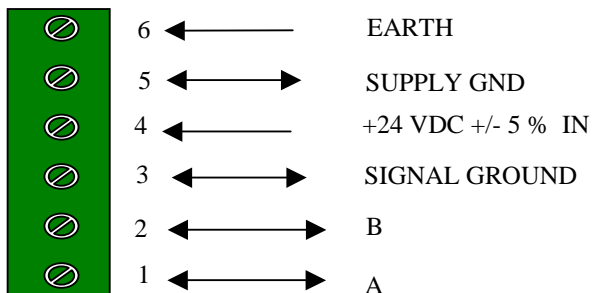

[III] For Gateway-PP

i) RS232C



ii) RS485

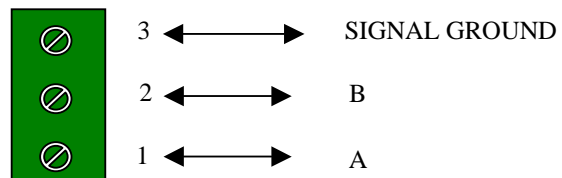

Getting Started

In this chapter....

- Introduction
- Project – Devices, Register Address and Blocks,
- Device communication

3.1 Introduction

Gateway is a Protocol Converter / Data sharer for devices like PLCs, inverters, Controllers. Gateway has two serial ports that connect with two different devices. These devices share data between themselves through Gateway. Gateway communicates with a device to get the information required by the device connected on the other port. The device that requires data is called Destination Device and the device that provides data is call Source Device. Information could be the value of a PLC register or the status of a PLC coil or Command from Source Device to Destination Device. Data flow through Gateway, which is controlled by the project, can be unidirectional as well as bi-directional.

3.2 Project – PLCs, Register Address, Blocks,

Microsoft Windows based configuration software, Gateway Setup, helps user to configure Gateway unit. 'Configuration' means making the Gateway unit work as per the system requirements. For example, Gateway can be configured to transfer data between two devices by execution of blocks. The complete configuration for a unit is termed as 'Project'. Project comprises of device names, Register addresses, Conditions for block execution etc.

Each register in a device memory has a unique address and this address can be directly used in Gateway project.

Each action to be taken by Gateway, which is configured in a Project, is known as a Block. Block may contain information like, copy number of Words, Bits etc from Source device to Destination device.

After the Project is defined, Drivers for defined devices and Project should be downloaded. Gateway now communicates with the connected devices and transfers data between them.

3.3 Device communication

Gateway can communicate with any device without any change in the Gateway hardware. To communicate with a device, Gateway needs:

1. Communication Drivers for the devices
2. Gateway – IBM PC communication cable for Configuration
3. Gateway - device communication cables

1. Communication Drivers for the devices:

Each device has a pre-defined protocol for communication. Communication driver varies from device to device. Gateway requires two drivers for communication, as two devices are connected for data sharing. These Communication Drivers are downloaded in to Gateway. These drivers enable Gateway to talk with devices.

2. Gateway – IBM PC communication cable for Configuration:

For Gateway to communicate properly with external Device, It should be configure for that device as per system requirement. For downloading Configuration/project, drivers, etc., Gateway needs on Configuration cable (IBM Cable). Pin-outs for that cable are as follows.

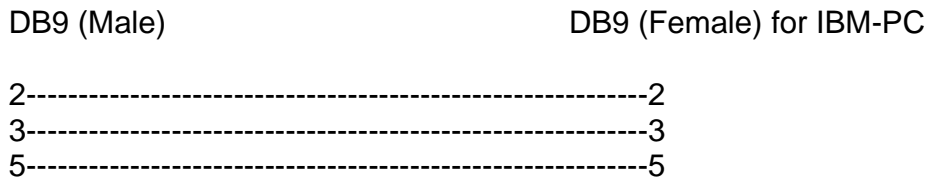

Please note that, power should be applied to Gateway while Configuration.

If Gateway is of type Gateway-PP then communication cable Pin-outs should be as follows.

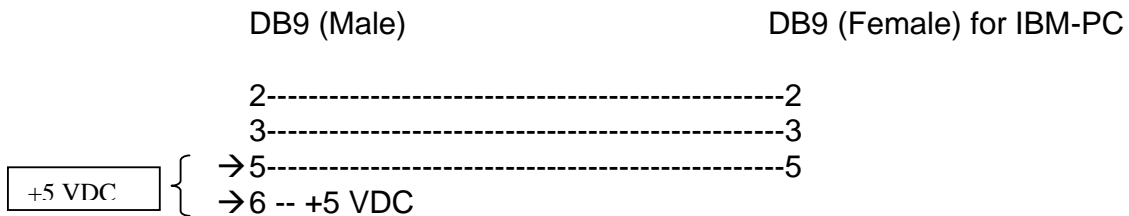

3. Gateway - device Communication Cable:

Proper Gateway - device cable is required for error free communication with any device.

Gateway Features

In this chapter....

- Repeat Cycle
- Control Word
- Error Indication Bit
- Selectable Baud rate
- LEDs for Communication Status

4.1 Repeat Cycle

User can control Block execution by using Repeat Cycle. Priority of Block execution is decided by means of Repeat Cycle. Range for Repeat Cycle is 1-99.

Repeat Cycle = 1 Highest priority
Repeat Cycle =99Lowest priority

Normally, Blocks are executed in step by step fashion. Eg. If 5 Blocks are defined in a project with Repeat cycle = 1, then Gateway executes blocks in following fashion.

Block execution starts with Block#01, then Block#02, ... Block#5 and again Block#01

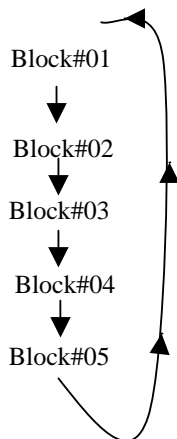

Execution of all the Blocks from Block#01 to Block#05 is treated as one cycle.

In above example

1. If Repeat Cycle =1 for every block except Block#04 which has Repeat Cycle =03
All the Blocks will be executed once after power-up.
Block#04 will be skipped for next 2 cycles.

Repeat Cycle 1 means Block will be skipped for 0 cycle means No skipping.

Repeat Cycle 2 means Block will be skipped for 1 cycles.

Repeat Cycle 3 means Block will be skipped for 2 cycles.

This is explained below.

1. In first cycle all blocks will be executed
Block#01,02,03,04,05

2. *In 2nd cycle only 4 blocks will be executed
....Block#01,02,03,05*
3. *In 3rd cycle only 4 blocks will be executed
Block#01,02,03,,05*
4. *In 4th cycle all blocks will be executed
Block#01,02,03,04,05*
5. *In 5 th cycle only 4 blocks will be executed
....Block#01,02,03,05*
6. *In 6th cycle only 4 blocks will be executed
Block#01,02,03,,05*
7. *In 7th cycle all blocks will be executed
Block#01,02,03,04,05*

4.2 Control Word

Another way of controlling Block execution is use of Control Word. This feature is extremely useful for small applications where less than 17 blocks are required. Control Word can be enable or disable while configuration of Gateway using Configuration Software. Normally Control Word is disable. It can enable just by clicking on check box in setup software. Control Word can be chosen from any of the Device connected.

When Control Word is disable Block execution is totally control by Repeat Cycle. But Repeat Cycle can only decides priority. Blocks, which are more important for process has to be, assigned high priority and those, which are less important for process has to be, assigned low priority.

When Control Word is enable Block execution is controlled using discrete bits of that word,

Bit0 in control word controls execution of Block 1
 Bit1 in control word controls execution of Block 2
 Bit2 in control word controls execution of Block 3
 Bit3 in control word controls execution of Block 4
 Bit4 in control word controls execution of Block 5
 .
 .
 .
 .
 Bit15 in control word controls execution of Block 16

Bit = OFF will stop execution of block
 Bit = ON will enable execution of block

This feature allows user to execute block in gateway whenever required, from outside. This avoids unnecessary execution of block and results in improvement of speed.

4.3 Error Indication Bit

This feature enables user to detect communication break, wire faults, Device power fail etc. at both ends of gateway. This is physical bit present in external device connected to gateway. Fault at com1 end is reported to com2 Device and fault at com2 end is reported to com1 Device by setting the bit in external device (Gateway sets this bit when error occurs).

Error indication bit can be enable or disable while configuration of Gateway using Configuration Software. Normally Error indication bit is disable. It can enable just by clicking on check box in setup software. Error indication bit can be enabled or disable in any of the Device connected to gateway.

Normally this bit is “OFF”, in case of abnormality in communication. This bit is set to “ON” by gateway , so that external device can know the problem. This useful to operator to take necessary action and avoid production losses.

4.4 Selectable Communication Parameters

Normally Gateway communicates with external devices with there default Communication Parameters. Selectable Communication Parameters for Communication Ports is very useful feature in Gateway, which allows user to change Baud rate, no. of stop bits, Parity etc. at any time without downloading Driver for that particular Device. Once you downloaded the driver for the external Device, you can change Communication Parameter, just by selecting new communication parameters and downloading the same project.

4.5 LEDs for Communication Status

Gateway has 3 LEDs on topside, which are useful for user to see communication status and gateway mode.

COM1 LED

Blinking of this LED indicates Communication is happening with Com1 Device.

If Com1 LED is not blinking then it indicates that, Com1 Device is not responding, no power to Com1 Device or Communication Cable Fault. This may also happen in case of invalid baud rate or Communication Parameters.

OK LED

When Configuration Cable is connected, and power is applied to Gateway, this led will blink at fast rate, indicates that Gateway is ready for configuration.

When proper PLC-Gateway Cable is connected and power is applied to Gateway, and if external Device is not responding or power is not applied to external Device or Communication cable is faulty, then this LED will blink at slow rate.

This LED will light on steady, when proper communication happens between Gateway and external Device.

COM2 LED

Slow blinking of this LED indicates Gateway is trying to Communicate with Com2 Device and device is not responding, no power to Com2 Device or Communication Cable Fault. This may also happen in case of invalid baud rate or Communication Parameters.

Fast blinking indicates that, Communication is happening with Com2 Device.

Configuration Software

Each Gateway has to be configured using Windows based configuration Software before connecting it to the PLC.

Configuration includes.

1. Create a new project
 - Select protocols both communication ports of gateway.
 - Create a blocks for data to be shared.
 - Set Communication Parameters.
 - Set Control Word.
 - Set Error Indication Bit, etc.

2. Downloading.
 - Download Project
 - Download new firmware if required (For upgradation)
 - Download new drivers (For different protocols)

If Devices to be connected to GATEWAY are specified while ordering, Downloading firmware and drivers is not needed. Firmware & drivers are already downloaded while shipment.

3. Upload Project.
Existing project in the gateway module can be seen.

4. Upload System Data.
This option enable user to see versions and status of firmware, drivers, and boot block.

How Do I Start?

User should follow the given sequence to configure and use any gateway unit.

1. Install GATEWAY Setup Software.
2. Create Gateway Project.
3. Connect IBM cable and power.
4. Download project in Gateway unit.
5. Now connect correct cables between external devices(PLCs, inverters etc.) and gateway.