

# idec Type HE3B ENABLING SWITCH



Use the ENABLING SWITCH according to the following instructions after confirming that the product is what you have ordered.

## ⚠ Safety Precautions

- Read this instruction sheet to make sure of correct operation before starting installation, wiring, operation, maintenance, and inspection. Also, keep this instruction sheet at the end user.
  - Turn off the power to the enabling switch before starting installation, wiring, maintenance, and inspection of the enabling switch.
- Failure to turn power off may cause electrical shocks or fire hazard.
- Use wires of proper size to meet voltage and current requirements. Using improper wires may cause fire hazard due to abnormal heat generation.

### (1) Application

The enabling switch permits machine operation only while the enabling switch is manually operated for robot teaching or other purposes in hazardous areas. Make sure that the control system is designed to activate the machine only when the enabling switch is at position 2 (A: 1mm/ B: 3mm operating stroke).

### (2) Type No. Development

**H E 3 B - M**

	<b>2</b>	<b>P</b>	<b>*</b>
3-position switch		Rubber boot	Rubber boot color
2: 2 contacts		Blank: Without rubber boot	Blank: Without rubber boot
		P: With a Rubber boot attached	Y: Yellow
			B: Black

### (3) Dimensions (mm)

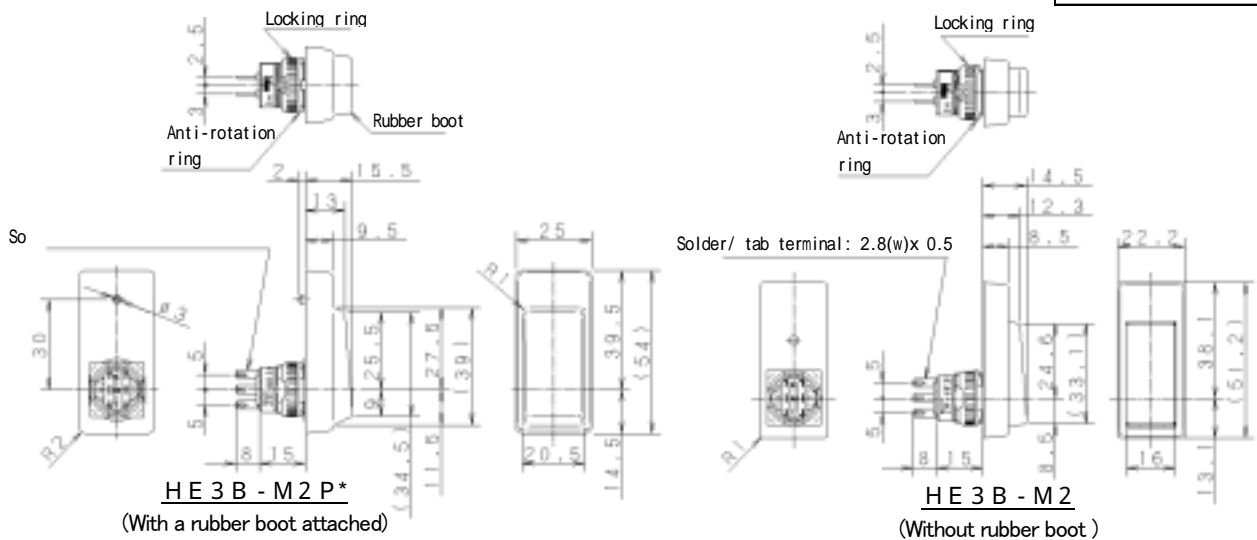

### (4) Mounting

- Mounting Hole Layout (mm)

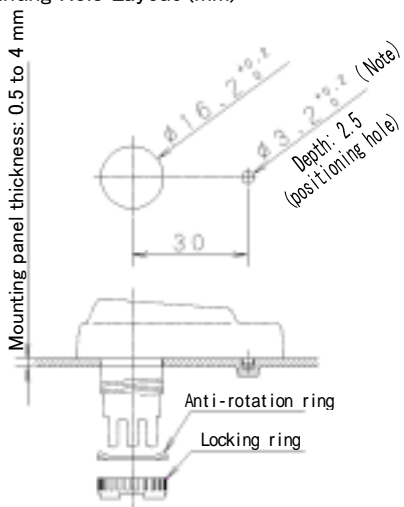

- Recommended tightening torque of locking ring:  
0.68 to 0.88 N·m  
Tighten the locking ring using the ring wrench  
(Type: MT-001).

Note: The rubber boot has a protrusion for orientation. When making a positioning hole on a panel, do not make a through hole; otherwise the waterproof characteristic will be impaired. When a positioning hole is not made on the panel, cut off the protrusion from the rubber boot, but do not make a perforation in the rubber boot.

Note: With an enabling switch with rubber boot mounted on a hermetically-sealed control box, a large change in internal air pressure may cause the rubber boot to expand and shrink, affecting the performance of the enabling switch. Check periodically to make sure that the enabling switch operates correctly.

Note: If the mounting panel is deformed when mounting an enabling switch with rubber boot, the normal waterproof characteristic is not assured. Keep a sufficient strength of the mounting panel.

Note: When tightening the locking ring, secure the flange part to prevent the enabling switch from rotating. In applications where the enabling switch may be rotated, mount the enabling switch in a recess on the panel as shown.



(5) Wiring

- Applicable Wire Size: 0.5 mm<sup>2</sup> (maximum) x 1 pc.
- Terminal Soldering: Solder at a temperature of 260 within 3 seconds. (Use non-corrosive liquid rosin as soldering flux.)

(6) Specifications and Ratings

Applicable Standards	IEC60947-5-1, EN60947-5-1 (DEMKO approval), JIS C8201-5-1 UL508(UL recognition), CSA C22.2 No.14(c-UL recognition)			
Applicable Standards for use	ISO12100/EN292, IEC60204-1/EN60204-1 ISO11161/prEN11161, ISO10218/EN775, ANSI/RIA R15.06			
Pollution Degree	2 ( inside the panel/ terminal side ) , 3 ( outside the panel/ operator side )			
Thermal Current < I <sub>th</sub> >	3A			
Contact Ratings (Reference Values) < U <sub>e</sub> , I <sub>e</sub> >	AC	Resistive load (AC12)	30V	125V
		Inductive load (AC15)	-	0.8A
	DC	Resistive load (DC12)	0.8A	0.2A
		Inductive load (DC13)	0.7A	0.1A
Impulse Withstand Voltage < U <sub>imp</sub> >	1.5 kV			
Conditional Short-circuit Current	50A 125V			
Short-circuit Protective Device	125V 10A Fuse (IEC60127-1)			
Degree of Protection	IP65: HE3B-M2P*			
	IP40: HE3B-M2			

(7) Configuration of Contacts and Number of Poles

3-position Switch (Note) 2 poles

...Terminal No.: between NO1 and C1, between NO2 and C2

Note: Use the NO and C terminals (OFF ON OFF).

(Do not use the NC terminals.)

Terminal Configuration (BOTTOM VIEW)

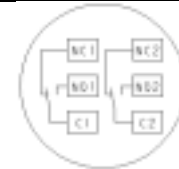

(8) Operating Characteristics ( pressing A and B: reference values )

Note: The operating force of the enabling switch with rubber boot depends on the ambient temperature.

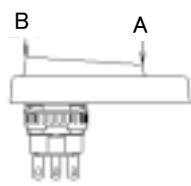

■ : ON (Close)  
□ : OFF (Open)

A: approx. 56 N  
B: approx. 14 N

Reference Operating Force  
(When the button is pressed.)

A: approx. 10 N  
B: approx. 2 N

Operating Travel (mm)

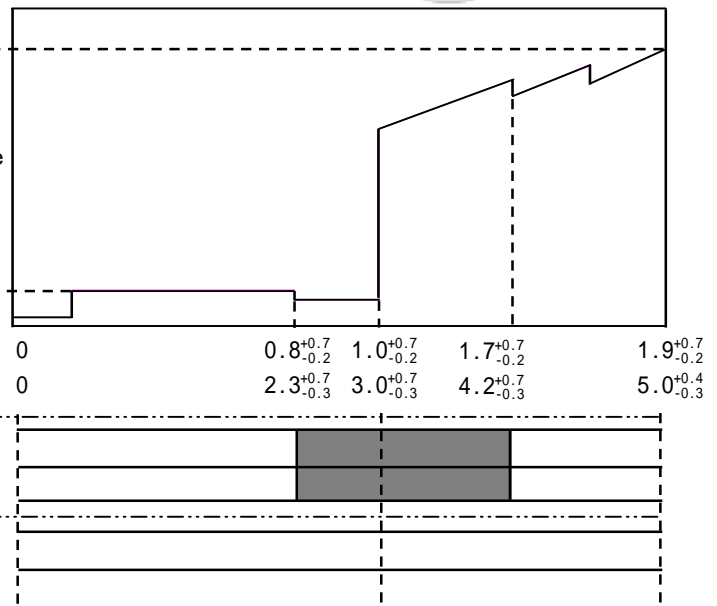

Push	NO1 - C1	■
	NO2 - C2	■
Release	NO1 - C1	□
	NO2 - C2	□

(9) Actuator Strength: 500N (minimum)

- when press the entire surface of the button -

(10) Accessory

- Replacement rubber boot:  
HE9Z-D3\* (Material: Silicon rubber)  
\*Rubber boot color ( Y: yellow, B: black )

Note: Install the rubber boot as shown at right.

Do not break the rubber boot during installation.

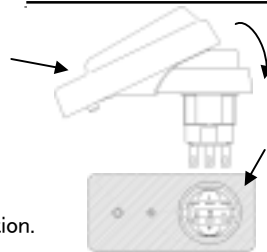

Installing the Rubber Boot

Put the long flange side into the rubber boot. (Keep foreign objects from entering the rubber boot to prevent malfunction.)

Wrap the rubber boot around the flange.

Viewing from the terminal side, check that the rubber boot is installed correctly on the ■ area.

Precautions for Operation

- Perform a sufficient risk assessment against the high operating force at transition to the OFF position when the button is pressed to the bottom.
- Perform a sufficient risk assessment against the shape and structure where the enabling switch is mounted, in order to prevent unintended actuation. For example, protrusion from a teaching pendant may cause the enabling switch to be actuated by the weight of the teaching pendant.
- When mounting the HE3B, make sure of sufficient strength of the mounting panel against the anticipated operating physical force. ( High operating physical force is expected especially at transition to the OFF position when the button is pressed to the bottom. )
- In order to ensure safety of the control system, connect each pair of the contacts of the 3-position switch to a discrepancy detection circuit such as a safety relay module. ( ISO13849-1/EN954-1 )