

● Before operating the switching power supply, read this instruction sheet and keep it for future reference.

1. Safety Standard Conditions

Applicable standard:UL508,UL1950,CSA No14,CSA No.950,EN60950,EN50178

Pollution degree :2
Leakage current :0.75mA Max.
EMC :EN50081-2,EN61000-6-2,EN61000-3-2,EN61000-3-3

2. Type No. Development

PS3L - ① ② ③ ④ ⑤

① Output Power

A : 10W, B : 15W, C : 30W, D : 50W, E : 100W, F : 150W, G : 300W

② Output Voltage

05 : 5V, 12 : 12V, 24 : 24V

③ Input Voltage

AF : 100-240VAC

④ Type & Style

Blank : Screw Terminal Type/Open Frame Style
A : Connector Type/Open Frame Style
C : Screw Terminal Type/Enclosed Style
D : Connector Type/ Enclosed Style
E : Angled Screw Terminal Type/Open Frame Style
F : Finger Protect Type/Enclosed Style
G : Angled Screw Terminal Type/ Enclosed Style
H : Screw Terminal Type/Enclosed Style (Other Cover Style)

⑤ Option

Blank : No Option
R : Remote Control (50W Over, Enclosed Style Only)
S : OCP Trimmer (100W Over)
T : With DIN Rail Attachment (100W Over)

3. Rating

Use the switching power supply with the output capacity within the values shown below.

PS3L-A

Input : 100-240VAC, 0.25A, 50-60Hz

Output:	Type	Output Voltage V DC	Output Current Max. A	Output Capacity Max. W
	A05	4.5- 5.5	2.0	10.0
	A12	10.8-13.2	0.9	10.8
	A24	21.6-26.4	0.5	12.0

PS3L-B

Input : 100-240VAC, 0.37A, 50-60Hz

Output:	Type	Output Voltage V DC	Output Current Max. A	Output Capacity Max. W
	B05	4.5- 5.5	3.0	15.0
	B12	10.8-13.2	1.4	16.8
	B24	21.6-26.4	0.7	16.8

PS3L-C

Input : 100-240VAC, 0.68A, 50-60Hz

Output:	Type	Output Voltage V DC	Output Current Max. A	Output Capacity Max. W
	C05	4.5- 5.5	6.0	30.0
	C12	10.8-13.2	2.5	30.0
	C24	21.6-26.4	1.3	31.2

PS3L-D

Input : 100-240VAC, 0.68A, 50-60Hz

Output:	Type	Output Voltage V DC	Output Current Max. A	Output Capacity Max. W
	D12	10.8-13.2	4.3	51.6
	D24	21.6-26.4	2.2	52.8

PS3L-E

Input : 100-240VAC, 1.4A, 50-60Hz

Output:	Type	Output Voltage V DC	Output Current Max. A	Output Capacity Max. W
	E12	10.8-13.2	8.5	102
	E24	21.6-26.4	4.5	108

PS3L-F

Input : 100-240VAC, 2.0A, 50-60Hz

Output:	Type	Output Voltage V DC	Output Current Max. A	Output Capacity Max. W
	F12	10.8-13.2	13.0	156
	F24	21.6-26.4	6.5	156

PS3L-G

Input : 100-240VAC, 3.8A, 50-60Hz

Output:	Type	Output Voltage V DC	Output Current Max. A	Output Capacity Max. W
	G24	21.6-26.4	12.5	300

4. Output Derating

Under applicable standard, max. temperature

40°C : Enclosed Style, Mounting A(PS3L-G), Mounting B(PS3L-E~G)

50°C : Enclosed Style, Mounting A(PS3L-A~F), Mounting B(PS3L-A~D)

Open Frame Style, Mounting A,B(PS3L-E~G)

60°C : Open Frame Style, Mounting A,B(PS3L-A~D)

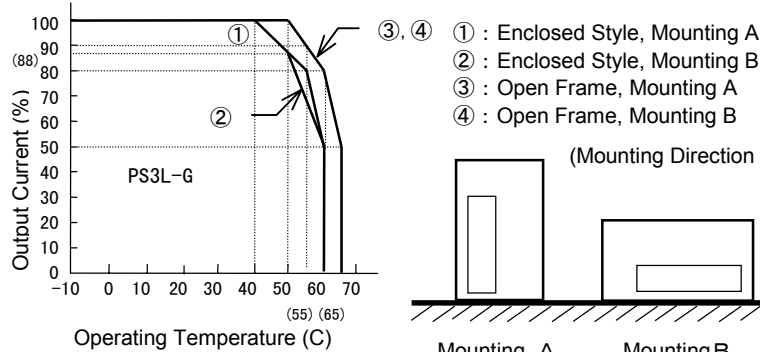
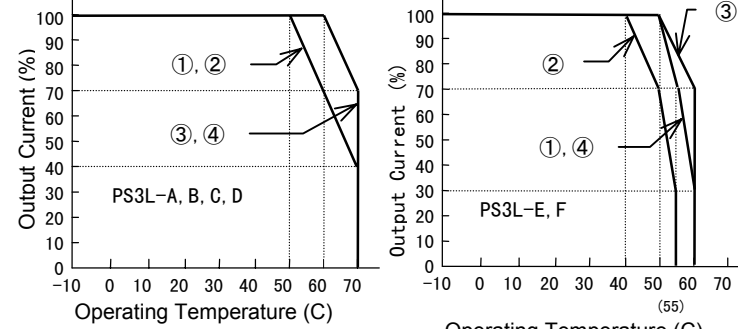

5. Power Supply Installation

① Mounting holes are provided on the bottom and one side.

Make sure that screws do not penetrate more than 6mm into the housing of switching power supply.

Use the Switching Power Supply with the Mounting Torque within the values shown below.

M3 : 0.5-0.7 N·m, M4 : 1.3-1.7 N·m

② Keep at least the following clearance around the switching power supply.

Type A to F : 20mm

Type G : 30mm

③ The switching power supply is for mounting inside equipment. Install the switching power supply so that a human body does not come into contact.

④ Terminal Torque 0.8 N·m. (Without Screwless Style)

⑤ Use minimum 60°C Wire

⑥ Use copper wire only.

⑦ When using the switching power supplies, connect all available output terminals of the same pole together.

⑧ The grounding terminal () of this power supply unit shall be connected to protective earthing in the end-product.

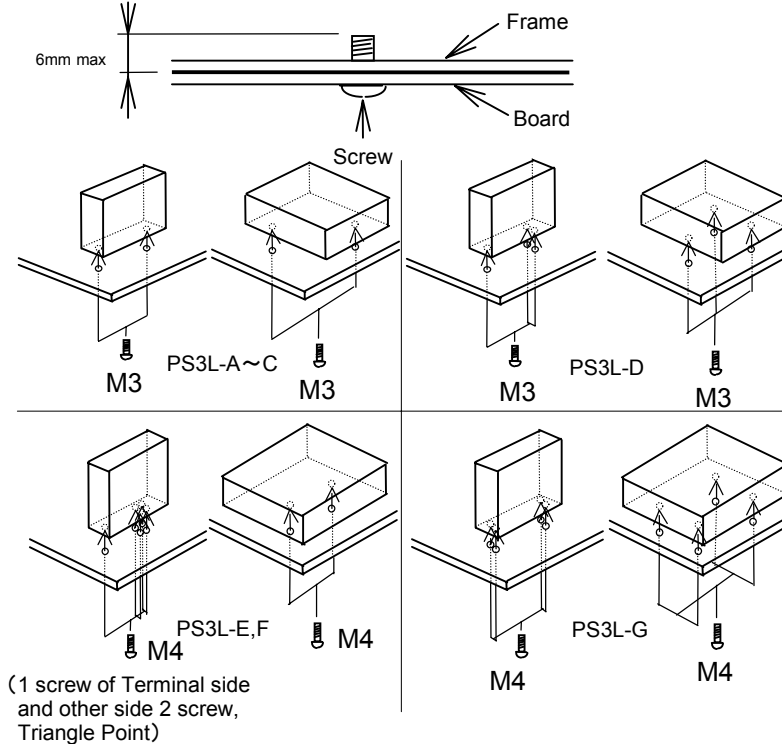

6. Terminal Marking and Description

① (N) AC Input Terminal

② (L) AC Input Terminal

③ () Ground Terminal

④ (-V) DC Output Terminal

(Connector Type: 1/2 terminals of Output Connector corresponds.)

⑤ (+V) DC Output Terminal

(Connector Type: 1/2 terminals of Output Connector corresponds.)

⑥ (V, ADJ) Output Voltage Adjustment Volume

⑦ (POWER) Operation Indicator

⑧ (-S) Remote Sensing Terminal

⑨ (+S) Remote Sensing Terminal

⑩ (RS) Remot Control Terminal

(Option : 50W Over, Enclosed Style Only)

(Note : Connect 5V to H and 0V to L, then Output Voltage is turned OFF)

PS3L-A, B, C, D

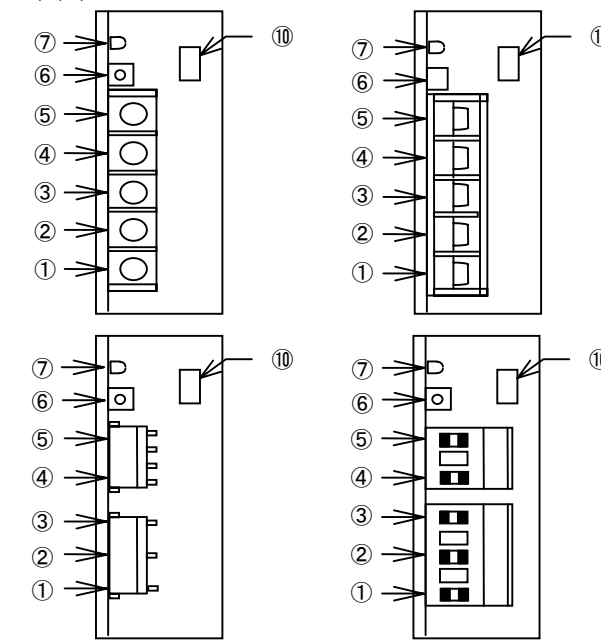

(Note) Output Connector
PS3L-A, PS3L-B : 2P
PS3L-C, PS3L-D : 4P

PS3L-E, F, G

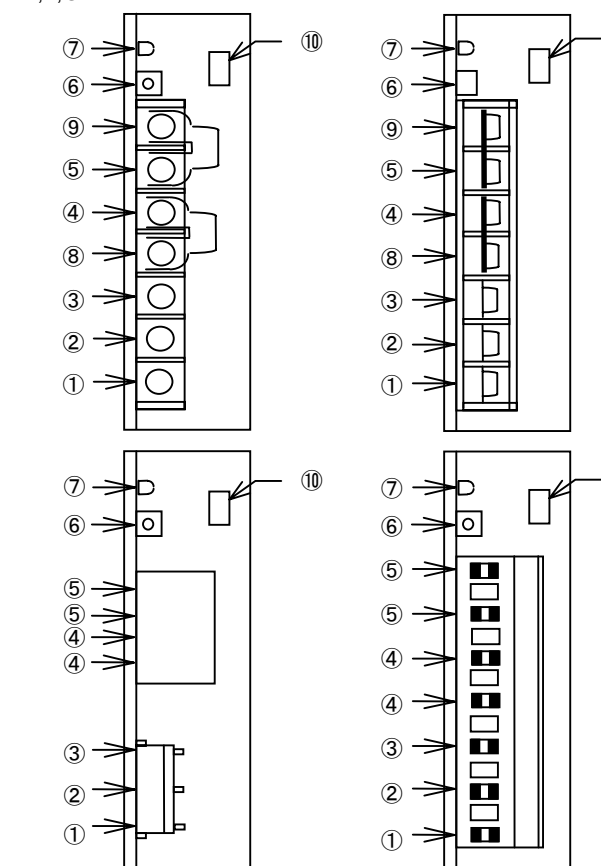

7. According to EN50178

Operating Temperature Range: -10~+70°C

(The highest operation temperature is different in the model or the mounted posture.)

Ambient Storage and Transit Temperature Range: -30~+75°C

(This temperature is applied for temporary period.)

Operating and Ambient Storage humidity: 20~90%RH

(without freezing and condensation)

Above Sea Level: 2000m(max.)

SAFETY PRECAUTIONS

- Read the following safety precautions to make sure of correct operation before starting installation, wiring, and operation.
- In this instruction sheet, safety precautions are categorized in order of importance to Warning and Caution:

WARNING Warning notices are used to emphasize that improper operation may cause severe personal injury or death.

WARNING

- Do not use the switching power supply on control equipment, aircraft, trains, and atomic equipment where malfunction of the switching power supply may cause severe personal injury or threaten human life. These switching power supplies are designed for use on general electronic equipment such as office equipment, communication equipment, and instrumentation equipment. This power supply is a unit of Class A. This means, that they can be used in all establishments other than domestic and those directly connected to a low voltage power supply network which supplies building used for domestic purposes.
- Make sure that the operating conditions satisfy the values described in the catalog. Confirm the specification values before designing the equipment to use the switching power supply and before supplying power. Contact IDEC if you have any question.
- Do not modify or repair the switching power supply. Modification or repairing of the switching power supply by users may cause electrical shocks, damage, fire, malfunction, and other heavy accidents.
- Do not install the switching power supply where a human body may come into contact while power is supplied to the switching power supply. Do not touch the switching power supply during operation or immediately after turning off because some parts are heated and at a high voltage, causing burns or electrical shocks. This switching power supply is designed for installation in equipment.
- Do not connect the output terminals together. Fire or damage may result. Include a protection in the equipment using the switching power supply in consideration of malfunction or damage of the load in case the switching power should fail. If the switching power supply should fail, a very high voltage drop may occur at the output terminals.
- Turn power off before wiring the switching power supply. Make sure of correct wiring. Incorrect wiring may cause electrical shocks or damage.

CAUTION Caution notices are used where inattention might cause personal injury or damage to equipment.

CAUTION

- Make sure of the correct input voltage. Incorrect input voltage may cause blown fuses, fuming, or fire. Make sure of correct polarity of input and output terminals before supplying power to the switching power supply.
- Do not touch any part inside the switching power supply. Prevent foreign objects from entering into the housing of the switching power supply. If the internal parts are touched by hand or foreign objects such as a paper clip or screw enters into the housing, accidents or damage may occur.
- Observe the temperature derating. The operating temperature is the temperature around the switching power supply. Use the switching power supply within the temperature derating curve. Otherwise, the internal temperature will rise and damage may be caused.
- Do not turn any part other than the output voltage adjustment. Otherwise, the switching power supply may be deteriorated and damage may be caused.
- When damage or malfunction should occur during operation, immediately turn power off and stop the switching power supply. Contact IDEC.
- Do not use or store the switching power supply in environments subjected to a large amount of vibrations or shocks. Otherwise, damage may be caused.
- Do not install the switching power supply in environments exposed to direct sunlight, iron particles, oil splashes, chemicals, and hydrogen sulfide. Do not use the switching power supply in humid places such as basements or greenhouses or in low-temperature places such as in freezers or in front of cooler outlet.
- When using the switching power supplies, connect all available output terminals of the same pole together, otherwise fire or smoke will result.