

# SA1W-MK1229

## Water Content Sensors

### Operating Instructions

IDEC IZUMI CORPORATION

#### NOTES FOR SAFETY

SA1W MK1229 unit is used to detect water or water content.

Do not use SA1W MK1229 unit for other purpose.

Read the operating instructions carefully before installation, wiring operation and maintenance and check. The operating instructions should be distributed to actual users.

#### NOTES FOR INSTALLATION

Do not use the sensor near an inductive machine and heat source, or where they are subject to strong shocks and vibrations, large amounts of dust, corrosive gases, water for a long period of time, oil and chemicals.

The light-receiving area should not be exposed to direct sunlight, incandescent light or fluorescence light.

Do not tighten the mounting screws excessively or tap a unit with hammer; otherwise, malfunction or damage may occur. The tightening torque for screw mounting should range from 0.5 to 0.8N·m.

#### NOTES FOR WIRING

Connect according to the output circuit diagram as mis-wiring will cause damage.

The power voltage should not exceed the rated range.

When using a switching power supply, be sure to ground the FG (frame ground) terminal.

Do not install high-voltage and power lines in the same conduit with input and output lines. Use separate conduit.

When wiring is long, or the influence of the power line and electromagnetic equipment may occur, use a separate conduit for wiring.

#### OPERATION AT POWER ON

The light source lamp does not go on immediately when power is turned on. The sensor contains a circuit to keep the output off for 20msec.

#### OTHER PRECAUTIONS

The lens is made of polycarbonate resin. Do not use organic solvent such as ammonia, caustic soda and benzene to clean the lens. Wipe any stain off the lens using a dry soft cloth or slightly dampened with ethanol solvent.

#### OPERATION MODE SELECTION

The operation mode can be selected by the operation mode selector on the top surface. To set to (D/ON), turn the operation mode selector clockwise to the extremes. To set to (L/ON), turn the operation mode selector counterclockwise to extremes.

IDEC IZUMI CORPORATION

NOTE Use the attached screw driver or a fit screw driver to turn the sensitive adjustment control. Care should be taken since excessive force may cause failure.

#### OPTICAL ALIGNMENT

The optical alignment described below is for Light ON mode.

- Turn a sensitivity adjustment control clockwise to the Max. position.
- Move the projector and receiver up, down, left and right. Then mount them in the middle of the range where the operation indicator (red) goes ON.
- Make sure that the stable indicator (green) goes on at incident and interruption.

\* For Dark ON, the lighting status of operation indicator is reversed

#### SENSITIVITY CONTROL

Order	Sensor status	Sensitivity Adjustment Control	Adjustment Procedure
1	Incident condition (without object)		First, at incident condition, turn the sensitivity adjustment control clockwise from Min. position until the operator indicator (yellow) goes ON (Point A).
2	Interrupt Condition (with object)		Second, in the interruption status, turn the sensitivity adjustment control further clockwise until the operator indicator (yellow) goes ON again (Point B). When the operation indicator does not go ON, Max. position is specified as point B.
3	-		Last, set the sensitivity adjustment control in the middle between A and B. This position is defined as Point C.

#### SPECIFICATIONS

SA1W-MK1229	
Detectable Object	Water or water content
Power Voltage	12 to 24V DC (Operating voltage: 12 to 24V DC) ripple 10% maximum
Setting Distance	200mm (for opaque resin container)
Current Draw	Projector: 30mA max. Receiver: 20mA max.
Output	NPN+PNP open collector NPN: DC 30V * 100mA max. Voltage drop 1.5V max.. PNP: DC 30V * 100mA max. Voltage drop 2.0V max.. Protect against short circuit
Operation Mode	Light ON or Dark ON (selectable by operation mode selector)
Response Time	10ms max.
Light Source Element	Infrared LD (Class 1: JIS C6802)
Receiver Element	Photodiode
Indicator	Projector: Power indicator, green LED (when power is on) Receiver: Operation indicator (yellow LED) / Stable operation indicator (green LED)
Operating Temperature	0□+45□ □without freezing□
Storage Temperature	-5□+50□ □without freezing□
Operating Humidity	35□85□RH □no condensation□
Extraneous Light Immunity	Incandescent light: 3,000lx maximum (on the receiver surface)
Degree of Protection	IP65
Material	Housing: PBT, Lens: Polycarbonate
Weight	Approx. 70g (receiver and projector, respectively)

#### INDICATOR

\* Operation indicator

\* Stable operation indicator

Operation indicator and Stable operation indicator operate according to the intensity level of the received light described below. Use the sensor under the stable incident or stable interruption mode.

Receiving light intensity level	Sensor status	Stable operation indicator (green)	Operation indicator (YELLOW)	
			Light ON	Dark ON
Light ON level	Stable incident	ON	ON	OFF
	Unstable incident	OFF	ON	OFF
	Unstable interruption	OFF	OFF	ON
	Stable interruption	ON	OFF	ON

#### Dimensions

##### Projector

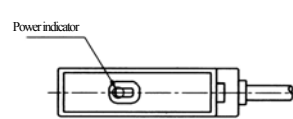

##### Receiver

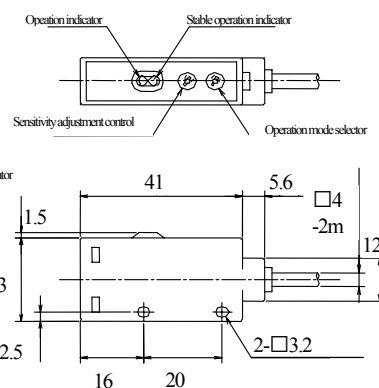

#### Output Circuit Diagram

\* Projector

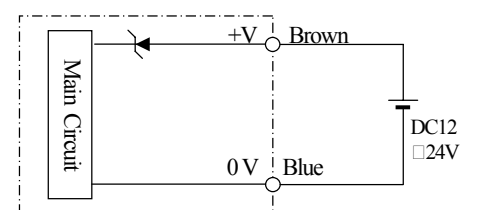

\* Receiver

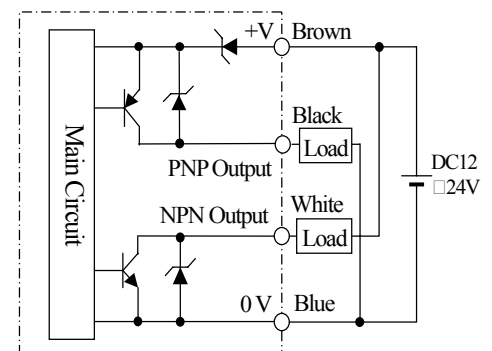

#### Operation Charts

