

AS-Interface Safety at Work Emergency Stop Switches

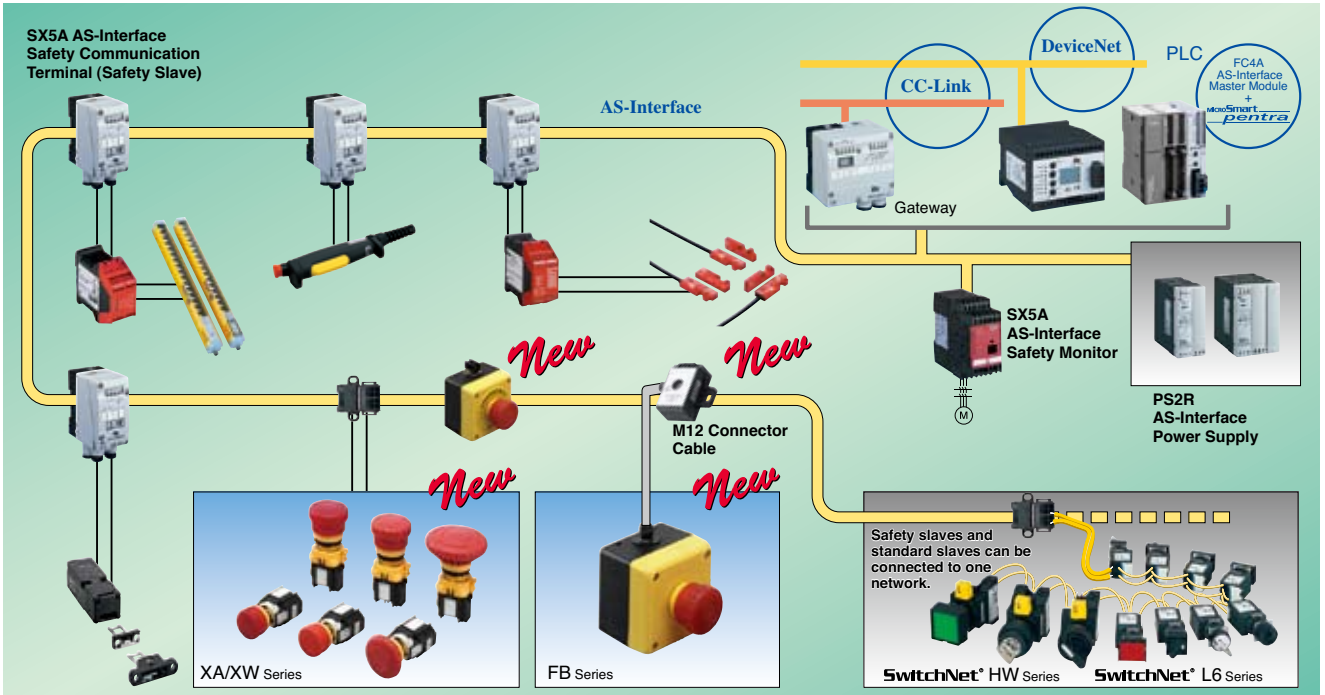

XA Series/XW Series/FB Series (Plastic Control Boxes)



Features

- Emergency stop switches with safety slave functions can be connected to the AS-Interface Safety at Work network.
- Complies with IEC 61508 SIL3 (Functional safety of electrical/electronic/programmable electronic safety-related systems) and EN 954-1 safety category 4 (Safety of machinery-Safety related parts of control systems).
- Space, wire, and labor-saving solutions for safety equipment
- Equipped with AS-Interface standard slave functions. Monitored with AS-Interface master devices.
- A wide variety of safety components
 - 1) 1-IN (non-illuminated types) and 1-IN/OUT (illuminated types) available.
 - 2) FB series plastic control boxes with $\phi 16\text{mm}$ XA series and $\phi 22\text{mm}$ XW series emergency stop switches available.
 - 3) $\phi 29\text{mm}$ and $\phi 40\text{mm}$ XA series emergency stop switches and $\phi 40\text{mm}$ and $\phi 60\text{mm}$ XW series emergency stop switches available.
 - 4) Terminal connectors such as which enable effective connection of switches and crimping and M12 terminal connectors are also available.



Types

$\phi 16\text{mm}$ XA Series

Operator Size	Connector Terminal	I/O Points	Illumination	Type No.	Button/Lens (*) Color Code
$\phi 29$	IDC	1-IN	Non-illuminated	XA1E-BV3Z10C1*	R: red RH: bright red N: gray ($\phi 29$ only)
		1-IN 1-OUT	Illuminated	XA1E-LV3Z114C1R	
$\phi 40$	IDC	1-IN	Non-illuminated	XA1E-BV4Z10C1*	
		1-IN 1-OUT	Illuminated	XA1E-LV4Z114C1R	

$\phi 22\text{mm}$ XW Series

Operator Size	Connector Terminal	I/O	Illumination	Type No.	Button/Lens (*) Color Code
$\phi 40$	IDC	1-IN	Non-illuminated	XW1E-BV4Z10C1*	R: red RH: bright red
	Crimping			XW1E-BV4Z10C2*	
	IDC	1-IN 1-OUT	Illuminated	XW1E-LV4Z114C1R	
	Crimping			XW1E-LV4Z114C2R	
$\phi 60$	IDC	1-IN	Non-illuminated	XW1E-BV5Z10C1*	
	Crimping			XW1E-BV5Z10C2*	

FB Series (Plastic Box + XW Series)

Operator Size	Connector Terminal	I/O Points	Illumination	Nameplate	Type No.	Button/Lens (*) Color Code
$\phi 40$	M12	1-IN 1-OUT	Non-illuminated	Without	FB1W-XW1E-BV4Z10C2--Y0-1	R: red RH: bright red
				With	FB1W-XW1E-BV4Z10C2--Y1-1	
$\phi 60$	AS-Interface Piercing	1-IN 1-OUT	Illuminated	Without	FB1W-XW1E-LV4Z114C2R-Y0-1	
				With	FB1W-XW1E-LV4Z114C2R-Y1-1	
$\phi 40$	AS-Interface Piercing	1-IN 1-OUT	Non-illuminated	Without	FB1W-XW1E-BV4Z10C2--Y0-2	
				With	FB1W-XW1E-LV4Z114C2R-Y0-2	
$\phi 60$	AS-Interface Piercing	1-IN 1-OUT	Illuminated	Without	FB1W-XW1E-LV4Z114C2R-Y1-2	
				With	FB1W-XW1E-LV4Z114C2R-Y1-2	
$\phi 60$	AS-Interface Piercing	1-IN	Non-illuminated	Without	FB1W-XW1E-BV5Z10C2--Y0-2	

Note: "EMERGENCY STOP" is engraved on the nameplate.

XA/XW/FB Series AS-Interface Emergency Stop Switches

General Specifications

Operating Voltage	26.5 to 31.6V DC (supplied from AS-Interface)
Rated Input Current	Illuminated type: 35 mA (XA series), 40 mA (XW, FB series) Non-illuminated type: 25 mA
Dielectric Strength	500V AC, 1 minute
Insulation Resistance	100 MΩ (500V DC megger)
Operating Temperature	XA, XW series: -25 to +55°C (no freezing) FB series: Illuminated type -25 to +50°C (no freezing) Non-illuminated type -25 to +55°C (no freezing)
Storage Temperature	-40 to +70°C (no freezing)
Operating Humidity	45 to 85% RH (no condensation)
Pollution Degree (IEC60664)	XA, XW series Operator unit: 3, Communication unit: 2 FB series: 3
Degree of Protection (IEC60529)	Operator unit: IP65 Terminal unit: IP20 (FB series: IP65)
Corrosion Immunity	Free from corrosive gases
Vibration Resistance	Damage limits/Operating extremes: 10 to 500 Hz, amplitude 0.35 mm, acceleration 50 m/s ²
Shock Resistance	Damage limits: 150 m/s ² Operating extremes: 1000 m/s ²
Weight (approx.)	XA series ø29: 35g, ø40: 40g XW series ø40: 60g, ø60: 70g FB series M12 connector: 195g (ø40), 205g (ø60) Piercing: 235g (ø40), 245g (ø60)

Mechanical/Electrical Specifications

Operating Force	Pushlock: 10.5N (XA series), 32N (XW, FB series) Pull reset: 10N (XA series), 21N (XW, FB series) Turn reset: 0.16N·m (XA series), 0.27 N·m (XW, FB series)
Minimum Force Required for Direct Opening Action	60N (XA series), 80N (XW, FB series)
Minimum Operator Stroke Required for Direct Opening Action	4.0 mm
Maximum Operating Stroke	4.5 mm
Operation Frequency	900 operations/hour
Mechanical Life	250,000 operations minimum
Electrical Life	250,000 operations minimum
Connectors	IDC connector (XA series) IDC connector, crimping connector (XW series) M12 connector/AS-Interface piercing connector (FB series)
Recommended Tightening Torque for Locking Ring	0.88 N·m (XA series), 2.0 N·m (XW series)

Communication Specifications

Communication	AS-Interface Ver. 3.0					
Slave Type	Safety slave					
Maximum Network Length	100m total					
Maximum No. of Slaves	31 (when only safety slaves are connected)					
Profile (I/O, ID, ID2)	S-7, B, E (illuminated type) S-0, B, E (non-illuminated type)					
Data Bit	Input	Emergency stop switch	D10	D11	D12	D13
	Output	When pressed	0	0	0	0
Parameter Bit	Input	Emergency stop switch	D10	D11	D12	D13
	When not pressed	X	X	X	X	X:0.1 (Unspecified)
Parameter Bit	Output	DO0 = 1	Pilot light: on			
	DO0 = 0	Pilot light: off				
Parameter Bit	Not used					

Accessories

Name	Specification	Type No.	Ordering Type No.
XA/XW Series IDC Connector Kit (*1)	End connector (with cover)	XW9Z-C100-1	XW9Z-C100-1PN05
	Through connector (with cover)	XW9Z-C100-2	XW9Z-C100-2PN05
IDC Connector Termination Tool	Manufactured by ITW Pancon	MMIT-156F	MMIT-156F
XW Series Connector Cable	Length 500 mm, without connector	XW9Z-C205	XW9Z-C205
	Length 1m, without connector	XW9Z-C210	XW9Z-C210
FB Series Control Box M12 Connector Cable	Length 300 mm, straight	FB9Z-CS03	FB9Z-CS03
	Length 1m, straight	FB9Z-CS10	FB9Z-CS10
	Length 2m, straight	FB9Z-CS20	FB9Z-CS20
	Length 1m, right-angle	FB9Z-CL10	FB9Z-CL10
	Length 2m, right-angle	FB9Z-CL20	FB9Z-CL20
Hand-held Programming Device	*2	SX9Z-ADR1N	SX9Z-ADR1N

*1: The package quantity is 5 pieces. IDC connector termination tool MMIT-156F (ITW Pancon) is required to connect the cable to the connector.

*2: Hand-held programming device accessories:
 • Programming device cable (SX9Z-CN1)
 • Programming device AC adapter (SX9Z-ADPT)
 • SwitchNet addressing port adapter (LA9Z-SNADP)

Dimensions/Panel Cut-out

• XA Series

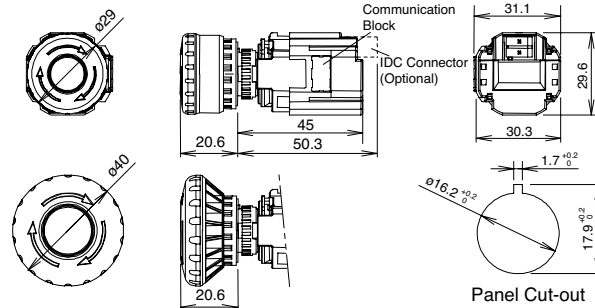

• XW Series

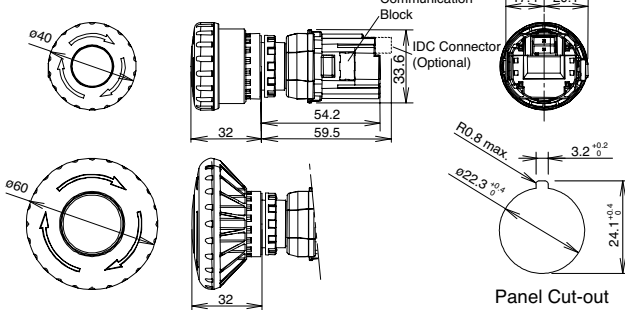

• FB Series

AS-Interface Piercing Type

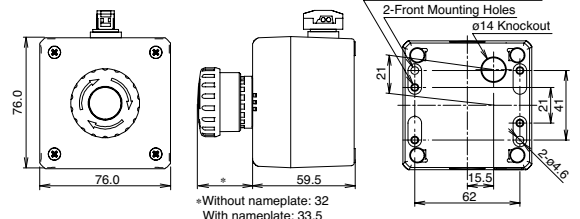

M12 Connector Type

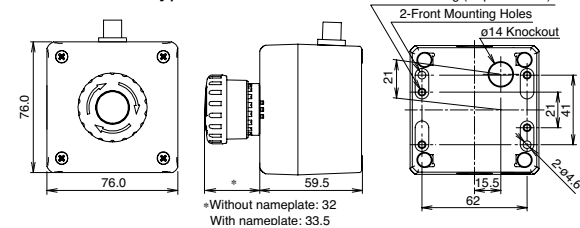

• M12 Connector Cable for FB Series Box

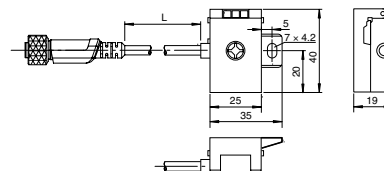

All dimensions in mm.

Specifications and other descriptions in this leaflet are subject to change without notice.



IDEC CORPORATION

7-31, Nishi-Miyahara 1-Chome, Yodogawa-ku, Osaka 532-8550, Japan
 Tel: +81-6-6398-2571, Fax: +81-6-6392-9731
 E-mail: products@idec.co.jp

IDEC CORPORATION (USA)
 Tel: +1-408-747-0550 / (800) 262-IDEC (4332)
 Fax: +1-408-744-9055 / (800) 635-6246
 E-mail: opencontact@idec.com

IDEC CANADA LIMITED
 Tel: +1-905-890-8561, Toll Free: (888) 317-4332
 Fax: +1-905-890-8562
 E-mail: sales@ca.idec.com

IDEC AUSTRALIA PTY. LTD.
 Tel: +61-3-9763-3244, Toll Free: 1800-68-4332
 Fax: +61-3-9763-3255
 E-mail: sales@au.idec.com

IDEC ELECTRONICS LIMITED
 Tel: +44-1256-321000, Fax: +44-1256-327755
 E-mail: sales@uk.idec.com

IDEC ELEKTROTECHNIK GmbH
 Tel: +49-40-25 30 54 - 0, Fax: +49-40-25 30 54 - 24
 E-mail: service@idec.de

IDEC (SHANGHAI) CORPORATION
 Tel: +86-21-5353-1000, Fax: +86-21-5353-1263
 E-mail: idec@cn.idec.com

IDEC IZUMI (H.K.) CO., LTD.
 Tel: +852-2803-8989, Fax: +852-2565-0171
 E-mail: info@hk.idec.com

IDEC TAIWAN CORPORATION
 Tel: +886-2-2698-3929, Fax: +886-2-2698-3931
 E-mail: service@idec.tw

IDEC IZUMI ASIA PTE. LTD.
 Tel: +65-6746-1155, Fax: +65-6844-5995
 E-mail: info@sg.idec.com