

# NRPS/NRPF P.C. BOARD CIRCUIT PROTECTORS

## Subminiature P.C. Board Mount Circuit Protectors Economical type like a fuse holder.

- SIL type subminiature circuit protectors adopting the IC terminal arrangement.
- Mountable directly on PC boards.
- Simple construction and high performance applying a positive load reversing mechanism by IDEC's original design.
- High reliability for protection against overcurrents.
- Unlike fuses, the thermal trip mode (bimetal type) eliminates erroneous interruption due to deterioration caused by inrush currents.
- Economically reusable after overcurrent interruptions.
- Available in slim and flat types.
- With a manual OFF mechanism convenient for circuit checkups.
- The rated current available in 7 types ranging from 1A to 6A.

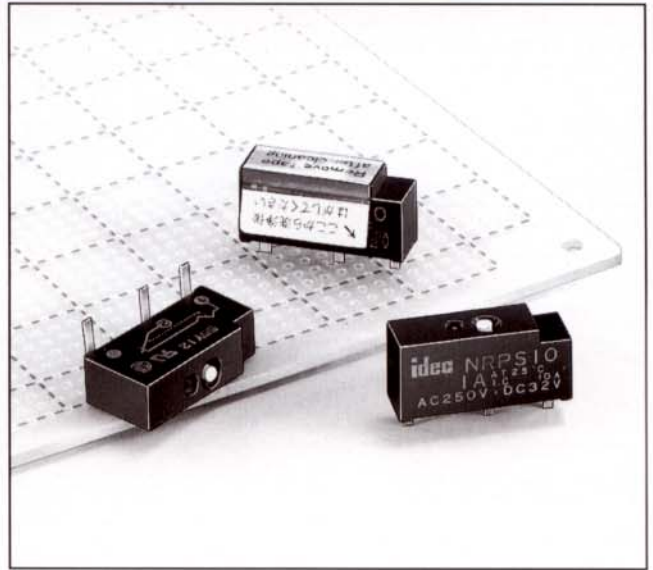

File No. E68029



File No. LR65560

### TYPES

• Specify the rated current in place of □ in the Type NO.

		Appearance	Type No.	Contact	Internal Circuit	Packaging Unit	Designations □ Rated Current
NRPS (Slim Type)	Non-sealed		NRPS10-□	1NC		50 pieces (23 pieces)	1A, 1.6A, 2A, 3.15A, 4A, 5A, 6A
	Sealed (Tape-sealed)		NRPS10-G□	1NC		50 pieces (23 pieces)	
NRPF (Flat Type)	Non-sealed		NRPF10-□	1NC		50 pieces	
	Sealed (Tape-sealed)		NRPF10-G□	1NC		50 pieces	

Note 1: Terminal ③ is provided for firm mounting on P.C. boards, without internal connections.

Note 2: ( ) represents stick packaging.

### TYPE NO. DEVELOPMENT

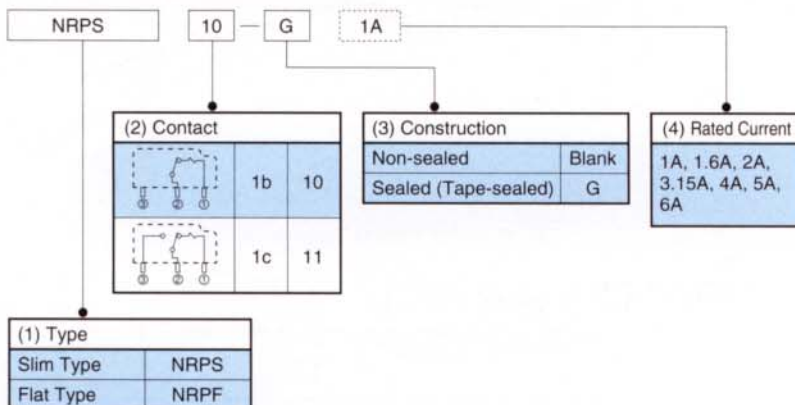

### ORDERING INFORMATION

- (1) When ordering, specify the Type No.
- (2) When stick packaging is required for P.C. board mounting, specify stick packaging. For details of stick packaging, contact IDEC.

# NRPS/NRPF P.C. BOARD CIRCUIT PROTECTORS

## • Notes for Type No. Selection

Application	Type No.	Slim Type		Flat Type	
		Non-sealed	Sealed	Non-sealed	Sealed
		NRPS10-□ NRPS11-□	NRPS10-G□ NRPS11-G□	NRPF10-□ NRPF11-□	NRPF10-G□ NRPF11-G□
Manual Soldering		○	○	○	○
Wave Soldering		×	○	×	○
Automatic Cleaning after Soldering		×	○	×	○
Automatic Mounting on P.C. boards		○	○	×	×

Note: The Sealed Type is provided with epoxy-seal on the base and with taping on the button part. After cleaning, be sure to remove the taping.

## SPECIFICATIONS

Protection Method	Thermal tripping
Internal Circuit	Series Trip
Number of Poles	1
Applicable Voltage	32V DC, 250V AC
Rated Current	1A, 1.6A, 2A, 3.15A, 4A, 5A, 6A
Rated Interrupting	1 to 4A: Rated current x 10 (resistive load) 5A and 6A: 250V AC, 40A, 32V DC: 40A (resistive load)
Reference Temperature	25°C
Operating Temperature	-10 to +50°C (without freezing)
Operating Humidity	45 to 85% RH
Reset Time	1 minute maximum (after tripping at 200% the rated current)
Vibration Resistance	100m/sec <sup>2</sup> (10 to 55Hz)
Shock Resistance	Damage limits:1000m/sec <sup>2</sup> Operating extremes:500m/sec <sup>2</sup>
Life	1 to 4A: 1,000 operations minimum (tripping at 200% the rated current) 5 and 6A: 200 operations minimum (tripping at 200% the rated current)
Insulation Resistance	100MΩ minimum (500V DC megger)
Dielectric Strength	Between the terminals of the same pole, between the live and dead parts: 1,500V AC (50/60Hz), 1 minute
Initial Contact	Between terminals ①and②: 200mΩ maximum (5V DC, 1A) Between terminals ②and③: 100mΩ maximum (5V DC, 100mA)
Weight (Approx.)	2g

Note: The rated current is the value at the reference ambient temperature of 25°C, and varies with operating temperature. The rated current can be corrected according to the Temperature Correction Curve.

## TIME DELAY CURVES

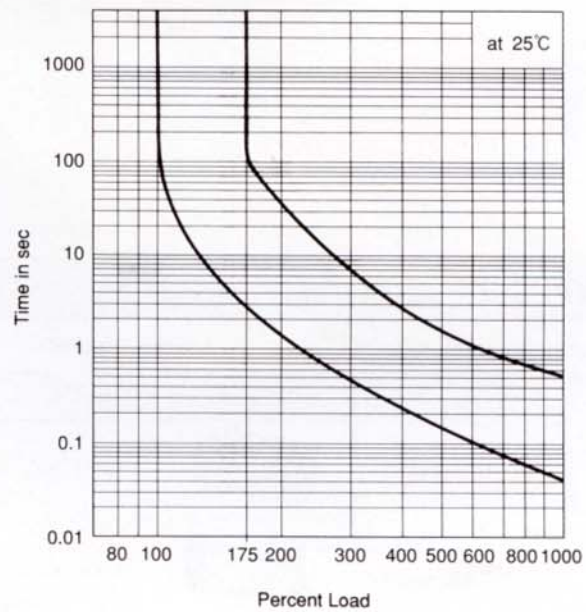

## TEMPERATURE CORRECTION CURVE

The rated current is based on an ambient temperature of 25°C. Since a thermal tripping method is employed, the rated current should be corrected according to the ambient temperature with reference to the curve shown below.

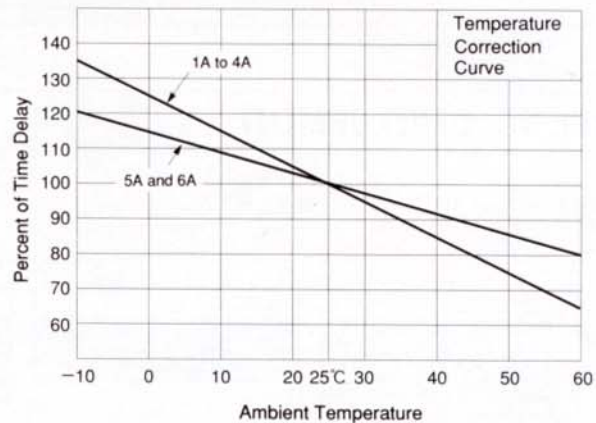

## OVERCURRENT-TIME DELAY CHARACTERISTICS (sec at 25°C)

Percent of Rated Current	100%	175%	200%	400%	600%	800%	1000%
Time Delay	NO TRIP	2.2-120	1.2-40	0.24-2.2	0.1-1	0.06-0.7	0.04-0.5

# NRPS/NRPF P.C. BOARD CIRCUIT PROTECTORS

## DIMENSIONS/P.C. BOARD LAYOUT GRID

### • Slim Type

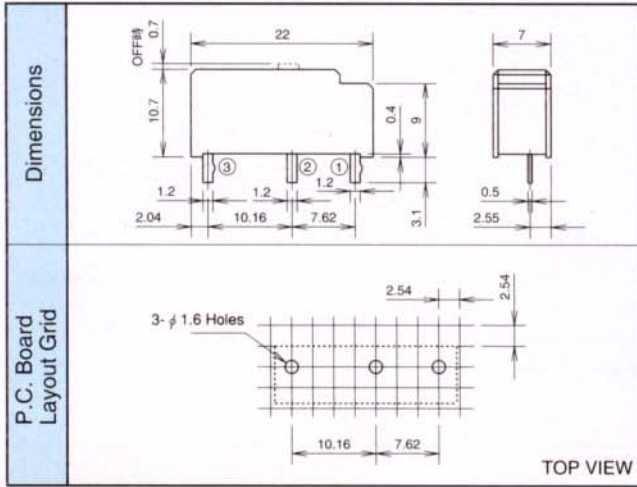

### • Flat Type

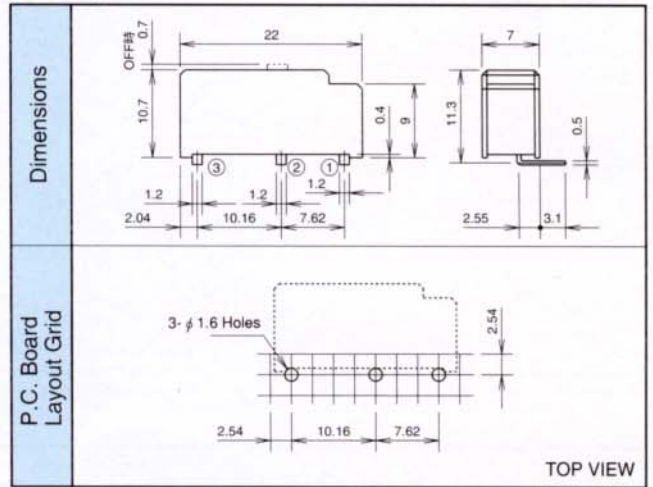

## REFERENCE DATA

### • Contact Resistance Test

5V · 100mA, Voltage Drop Method,  
Shipment Inspection (initial value)  
Measuring Resistance Between  
terminals ① and ②.

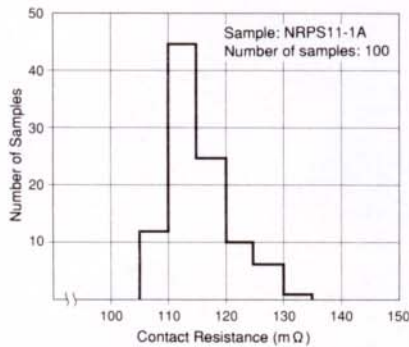

5V · 100mA, Voltage Drop Method,  
Shipment Inspection (initial value)  
Measuring Resistance Between  
terminals ② and ③.

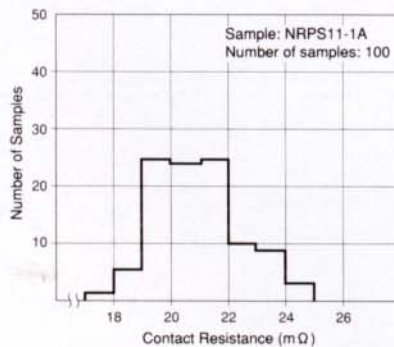

5V · 1A, Voltage Drop Method,  
Shipment Inspection (initial value)  
Measuring Resistance Between  
terminals ① and ②.

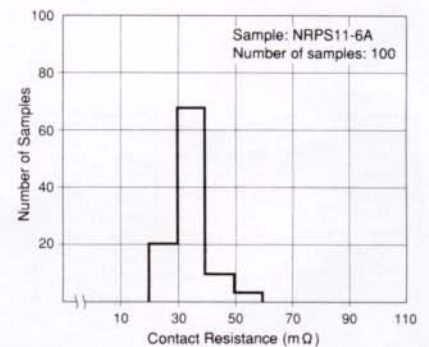

### • Time Delay Curve Test (1A Type)

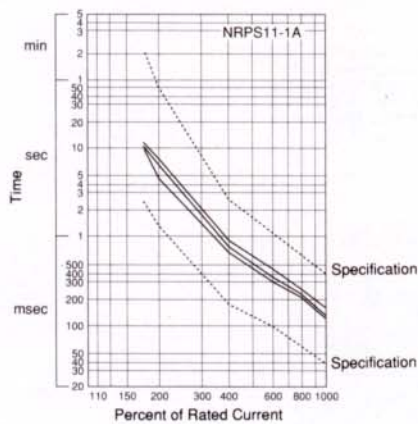

### • Time Delay Curve Test (2A Type)

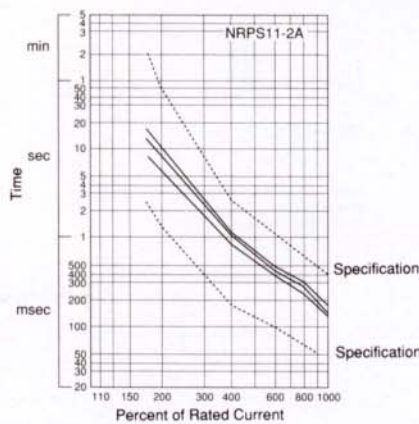

### • Time Delay Curves varies with Ambient Temperature.

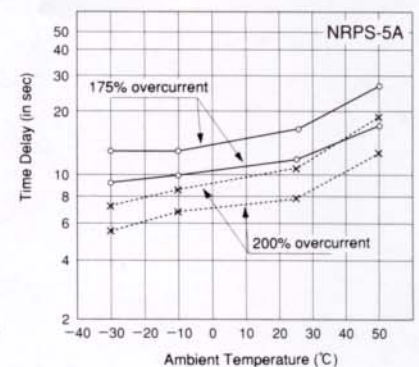

# NRPS/NRPF P.C. BOARD CIRCUIT PROTECTORS

## REFERENCE DATA

### • Shock Test (at Power Off)

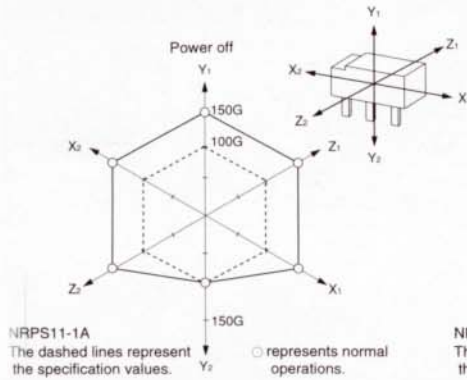

### • Shock Test (5V DC, 1A)

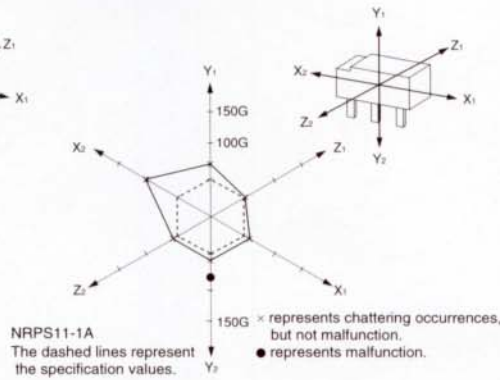

### • Vibration Test (5V DC, 1A)

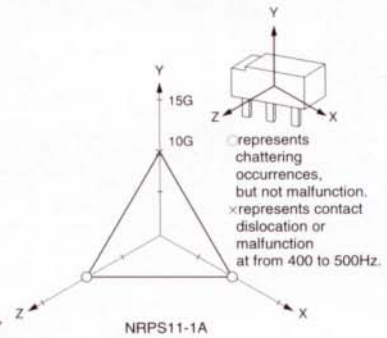

### • Dielectric Strength Test

NRPS11 | 100 units in total  
NRPF11 |

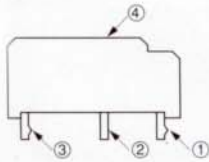

Item	1,500V AC, 1 minute	Critical Values		
		X	MIN	MAX
Between terminals ①-② and ③	Normal	2800	1700	3400
Between terminals ②-③ and ①	Normal	2740	2700	3400
Between housing and terminal ④-①&②&③	Normal	3600	3300	3800

### • Short-circuit Test (AC)

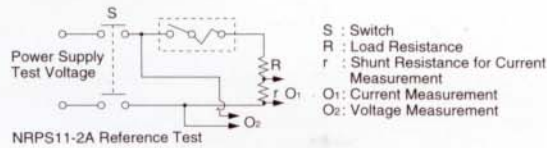

Data  
Power Voltage: 220V AC, Frequency: 60Hz  
Short-circuit current (short-circuit current): 20A  
Power factor:  $\cos \phi = 1$  (after 4 cycles when power is applied)

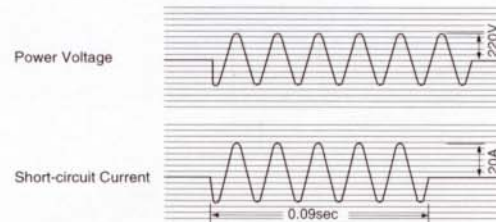

### • Short-circuit Test (DC)

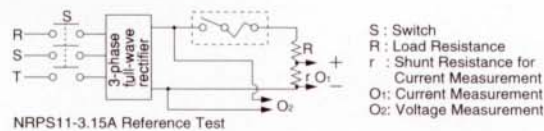

Data  
Power Voltage: 32V DC  
Short-circuit current: 31.5A

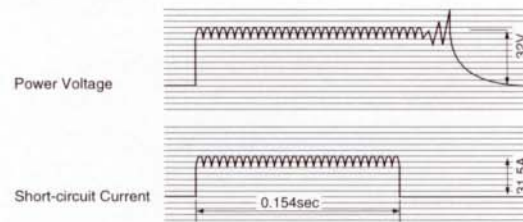

# NRPS/NRPF P.C. BOARD CIRCUIT PROTECTORS

## APPLICATIONS

The NRP series circuit protectors are ideal for use on P.C. boards in small electric appliances to protect control circuits from overload. In addition to subminiature size and high performance, the capability of over 1,000 repeated uses will find a wide range of applications in place of various fuses.

## APPLICATION EXAMPLES

Office Automation Equipment: Copiers, Shredders, Facsimiles  
Medical Equipment: Medical Equipment,  
Health-Promotion Equipment  
Machine Tools: Robots, Hydraulic machines  
Measuring Equipment: Testers, Oscilloscopes  
Communication Equipment: Transmitter/Receiver, Telephone Exchanger  
Power Supplies: Switching Power Supplies,  
Small Generators.

## INTERNAL CIRCUITS EXAMPLE

Transformer Protection  
Example  
Transformer Primary Protection

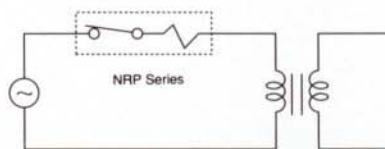

Transformer Secondary Protection

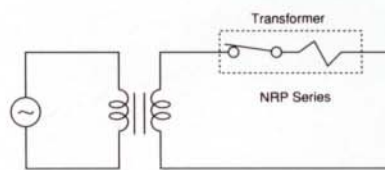

Rectifier Protection  
Example

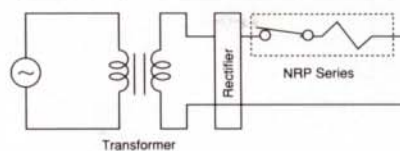

Motor Coil Protection

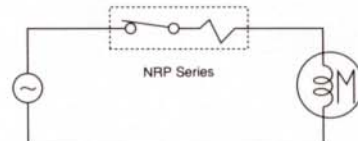

Specifications and other descriptions in this catalog are subject to change without notice.

---



## **IDEC IZUMI CORPORATION**

7-31, Nishimiyahara 1-Chome, Yodogawa-ku, Osaka 532, Japan  
Phone: (06) 398-2571, Telex: 523-3710, Facsimile: (06) 392-9731

---

**IDEC CORPORATION (USA)**  
1213 Elko Drive, Sunnyvale, CA 94089-2240, USA  
Phone: (408) 747-0550, Facsimile: (408) 744-9055

**IDEC CANADA LIMITED**  
Unit 22-151, Brunel Road Mississauga, Ontario L4Z, 1X3 Canada  
Phone: (905) 890-8561, Facsimile: (905) 890-8562

**IDEC AUSTRALIA PTY. LTD.**  
2/3 Macro Court, Rowville, Victoria 3178, Australia  
Phone: (61) 3-9763-3244, Facsimile: (61) 3-9763-3255

**IDEC ELEKTROTECHNIK GMBH**  
Wendenstraße 331, D-20537 Hamburg, Germany  
Phone: 0 40-25 11 91-93, Facsimile: 0 40-254 33 61

**IDEC ELECTRONICS LIMITED**  
Unit 12, Canbury Business Park Elm Crescent, Kingston-Upon-Thames,  
Surrey KT2 6HJ, UK  
Phone: 0181 549 0737, Facsimile: 0181 546 0963

**IDEC IZUMI (H.K.) CO., LTD.**  
Room 1409, Tower 1, Silvercord, 30 Canton Road, Tsimshatsui,  
Kowloon, Hong Kong  
Phone: (852) 2376-2823, Facsimile: (852) 2376-0790

**IDEC TAIWAN CORPORATION**  
3F, No.75, Hsin Tai Wu Road, Sec. 1, Hsi-Chih, Taipei County, Taiwan, R.O.C.  
Phone: (886)-2-698-2601, Facsimile: (886)-2-698-2709

---