

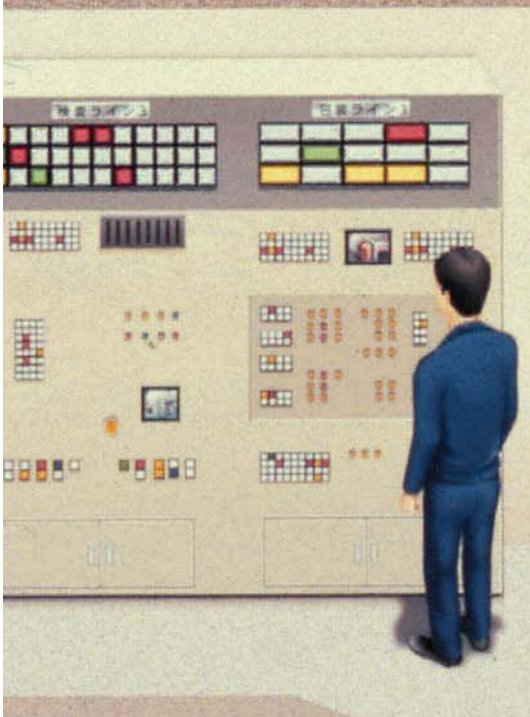









# Ø22mm TW Series





Control Units





























## ø22 TW Series Control Units (Selection Guides)









Function	Pushbutton				
Category	Flush	Extended	Extended w/Full Shroud	ø29mm Mushroom	ø40mm Mushroom
Shape	Momentary/Maintained				
Shape					
Type	ABW1 AOW1	ABW2 AOW2	ABFW2 AOFW2	ABW3 AOW3	ABW4 AOW4
Page	8	8	8	8	9





















Function	Pushbutton				
Category	ø40mm Mushroom w/Full Shroud	ø29mm Mushroom	ø40mm Mushroom	ø40mm Mushroom	ø29mm Mushroom
Shape	Momentary				
Shape					
Type	ABGW4	AVW3	AVW4	AJW4	AXW3
Page	9	9	9	9	9

Function	Pushbutton			
Category	ø40mm Mushroom	ø40mm Mushroom	Square Flush	Square Extended
Shape	Momentary/Maintained			
Shape				
Type	AXW4	AYW4	ABQW1 AOQW1	ABQW2 AOQW2
Page	10	10	10	10

Function	Pilot Light		
Category	Flush (Non-marking/Marking)	Dome	Square Flush (Marking)
Shape	Momentary/Maintained		
Shape			
Type	APW1 APW1B	APW2	UPQW1B
Page	11	11	11

Function	Illuminated Pushbutton (LED/Incandescent)				
Category	Extended (Non-marking/Marking)	Extended w/Full Shroud (Non-marking/Marking)	Square Extended (Marking)	ø29mm Mushroom Pushlock Turn Reset	ø40mm Mushroom Pushlock Turn Reset
Shape	    	    	    	   	   
Type	ALW2, ALW2B, AOLW2, AOLW2B	ALFW2, AOLFW2 ALFW2B, AOLFW2B	ALQW2B AOLQW2B	AVLW3 AVLW3B	AVLW4 AVLW4B
Page	13, 14	15, 16	17	18	19

Function	Illuminated Pushbutton (Incandescent)	
Category	ø29mm Mushroom (Non-marking/Marking)	ø40mm Push-Pull
Shape	    	   
Type	ALW3, ALW3B, AOLW3, AOLW3B	AYLW4 AYLW4B
Page	18	19

Function	Selector Switch			Illuminated Selector Switch (LED/Incandescent)
Category	Knob	Lever	Key	Knob
Shape	    	    	    	    
Type	ASW	ASW*L	ASW*K	ASLW
Page	22	23	24	25, 26

# ø22 TW Series Control Units

**General-purpose control units for various applications**  
**Heavy-duty type for high-level protection against harsh environment**

Low Voltage Directive  
 EMC Directive



- Highly reliable HW contact blocks are used.
- Degree of protection: IP65 (IEC 60529)
- UL and CSA approved, EN compliant

Safety Standards	File No. or Organization
UL	UL Listing File No. E68961
CSA	File No. LR21451
EN EN60947-1 EN60947-5-1	TÜV Rheinland

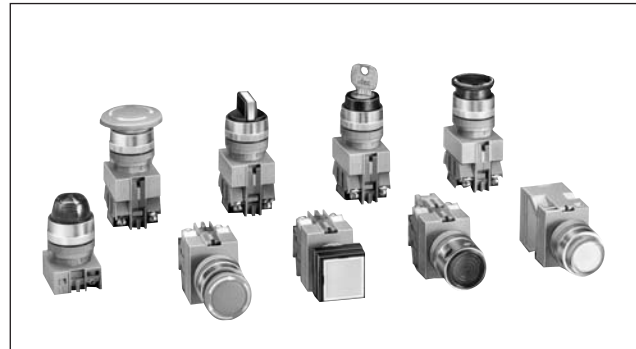

## Specifications and Ratings

### Contact Ratings

Contact Block	Rated Insulation Voltage	600V
	Rated Continuous Current	10A
	Contact Ratings by Utilization Category IEC 60947-5-1	AC-15 (A600) DC-13 (P600)

### Characteristics

#### • Contact Ratings by Utilization Category

Operational Voltage		24V	48V	50V	110V	220V	440V
Operational Current	AC 50/60 Hz	AC-12 Control of resistive loads and solid state loads	10A	—	10A	10A	2A
		AC-15 Control of electromagnetic loads (> 72 VA)	10A	—	7A	5A	1A
	DC	DC-12 Control of resistive loads and solid state loads	8A	4A	—	2.2A	1.1A
		DC-13 Control of electromagnets	4A	2A	—	1.1A	0.6A

Minimum applicable load: 3V AC/DC, 5 mA (applicable range may vary with operating conditions and load types)

For the control units listed below, the rated current (load switching current) is reduced to a half of the rated operational current of the contact block. The rated insulation voltage (600V) and the rated thermal current (10A) remain unchanged.

- Selector switches and illuminated selector switches with contact code 2S, 3S, 4S, 2R, or 4R.

### HW-C (Contact Block)

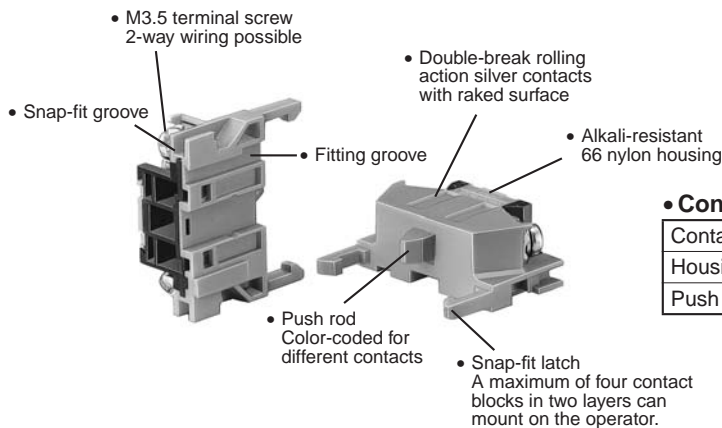

#### • Contact Block Types

Contact	NO	NC	NO (early make)	NC (late break)
Housing	Blue	Purple red	Blue	Purple red
Push Rod	Green	Red	Black	White

### Incandescent Lamp Ratings (LS Type)

Type No.	LS-6	LS-8	LS-2	LS-3
Lamp Base	BA9S/13			
Rated Voltage	6V AC/DC	12V AC/DC	18V AC/DC	24V AC/DC
Wattage	1W (6.3V)	1W (18V)	1W (24V)	1W (30V)
Voltage Marking	Die stamped on the base			
Life (reference value)	Approx. 1,000 hours minimum (mean value when used on the rated voltage)			

**LED Lamp Ratings (LSTD Type)**

Type No.	LSTD-6 <sup>②</sup>	LSTD-1 <sup>②</sup>	LSTD-2 <sup>②</sup>
Lamp Base	BA9S/13		
Rated Voltage	6V AC/DC	12V AC/DC	24V AC/DC
Voltage Range	6V AC/DC ±10%	12V AC/DC ±10%	24V AC/DC ±10%
Current Draw	AC	A, R, W, Y: 17 mA, G, PW, S: 8 mA	11 mA
	DC	A, R, W, Y: 14 mA, G, PW, S: 5.5 mA	10 mA
Color Code <sup>②</sup>	A (amber), G (green), PW (pure white), R (red), S (blue), W (white), Y (yellow)		
Lamp Base Color	Same as illumination color		
Voltage Marking	Die stamped on the base		
Life (reference value)	Approx. 50,000 hours (The luminance reduces to 50% the initial intensity when used on complete DC.)		
Internal Circuit	A, R, W, Y		
	G, PW, S		

**Specifications**

Operating Temperature	-25 to +50°C (no freezing)
Storage Temperature	-40 to +80°C
Operating Humidity	45 to 85% RH (no condensation)
Contact Resistance	50 mΩ maximum (initial value)
Insulation Resistance	100 MΩ minimum (500V DC megger)
Dielectric Strength	Between live and dead metal parts: 2,500V AC, 1 minute (Full voltage type illuminated units: 2,000V AC, 1 minute)
Vibration Resistance	Operating extremes: 5 to 55 Hz, amplitude 0.5 mm
Shock Resistance	Damage limits: 1,000 m/s <sup>2</sup> Operating extremes: 100 m/s <sup>2</sup>
Mechanical Life (minimum operations)	Pushbuttons, Illuminated pushbuttons Momentary: 5,000,000 Others: 500,000 Selector switches: 500,000 Illuminated selector switches: 500,000
Electrical Life (minimum operations)	Pushbuttons: 500,000 (switching frequency 1,800 operations/h, duty ratio 40%) Illuminated pushbuttons: 500,000 (switching frequency 1,800 operations/h, duty ratio 40%) Selector switches: 500,000 (switching frequency 1,200 operations/h, duty ratio 40%)

**Mounting Hole Layout**

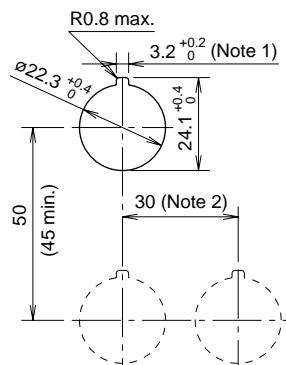

Note 1: The 3.2 mm recess is for preventing rotation and is not necessary when the nameplate or anti-rotation ring is not used.

Note 2: The minimum mounting centers are applicable to switches with one layer of contact blocks (two contact blocks). When two layers of contact blocks are mounted, determine the minimum mounting centers in consideration of convenience for wiring.

- ø40mm mushroom: 40 mm minimum
- 2-position, 3-position lever type selector switch: 39 mm minimum
- 4-position, 5-position lever type selector switch: 50 mm minimum

**Degree of Protection**

Type No.	Unit	NEMA ICS 6-110	IEC 60529
A****	Pushbuttons, pilot lights, illuminated pushbuttons, and selector switches	Type 1, 2, 3, 3R, (3S), 4, 5, 12,13	IP65
	Illuminated selector switches, key pushbuttons, key reset pushbuttons, and key selector switches	Type 1, 2, 3R, 5, 12, 13	IP54

Note: (3S) of NEMA ICS 6-110 applies to the pilot lights with round lens.

# ø22 TW Series Control Units (Ordering Information)

## Ordering Information

- Specify an operator or lens color code in the Type No.
- Full voltage type illuminated units are not supplied with a lamp. Order LED or incandescent lamps separately. Transformer and DC-DC converter type illuminated units contain an LED or incandescent lamp.
- When a terminal cover is required, order an applicable terminal cover referring to page 30.

Rated Voltage	LED Lamp	Incandescent
100/110V AC	LSTD-6②	LS-6
200/220V AC	LSTD-6②	LS-6
110V DC	LSTD-6②	LS-6

- All standard units are UL, CSA, EN, and TÜV approved.

The Type No. development charts shown below can be used to specify control units other than those listed on the following pages. Gold-plated silver contacts are also available.

### Pushbuttons

#### ABW1 11 R - MAU

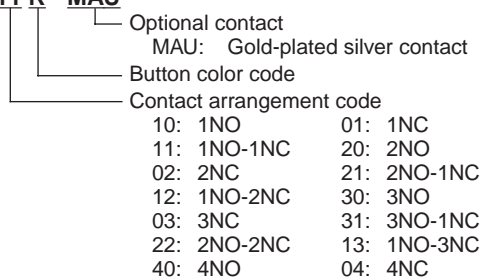

Note:

- Push-pull type AYW4 can have a maximum of two contact blocks.

### Pilot Lights

#### APW2 116 D R

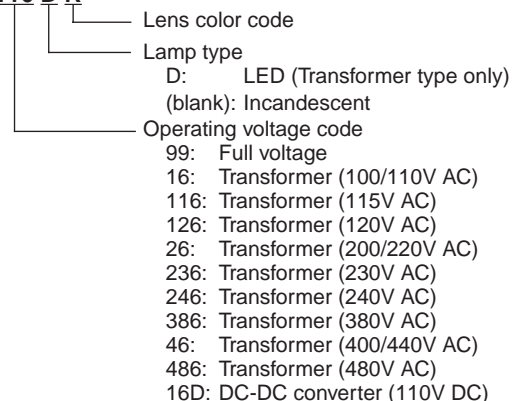

Note:

- Full voltage type is not supplied with a lamp.
- Transformer and DC-DC converter types contain an LED lamp (LSTD-6②) or incandescent lamp (LS-6).

### Illuminated Pushbuttons

#### ALFW2 116 13 D R - MAU

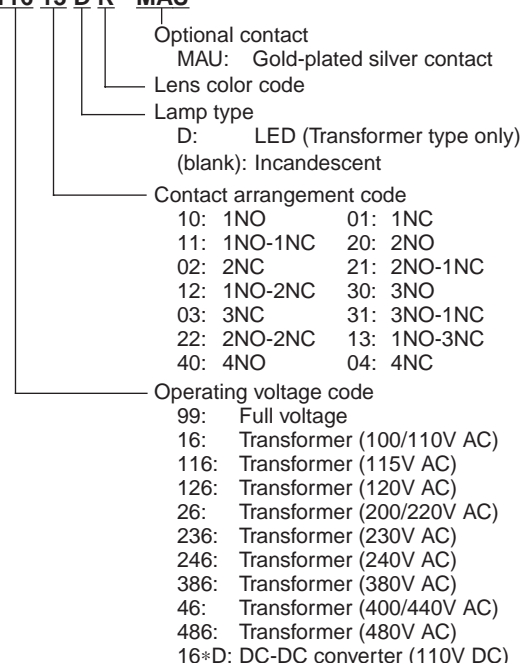

Note:

- Push-pull type AYLW4 can have a maximum of two contact blocks.
- Transformer type and DC-DC converter type cannot have an odd number of contact blocks, such as 1NO, 1NC, 3NO, 2NO-1NC, 1NO-2NC, and 3NC.

## Selector Switch

### ASW 2 L 11 - MAU

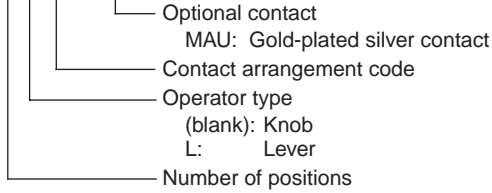

Note:

- See pages 26 to 28 for contact arrangement codes.

## Key Selector Switch

### ASW 2 K 20 B - MAU

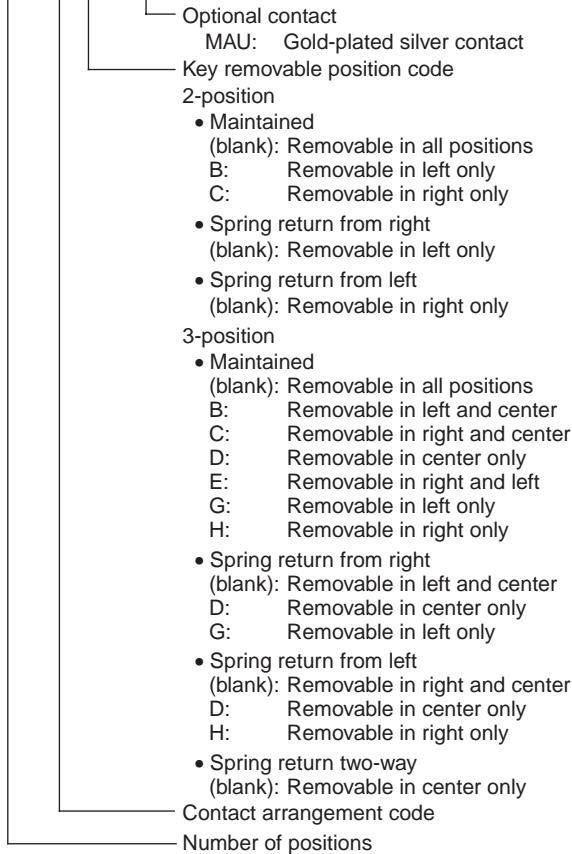

Note:

- See pages 27 to 29 for contact arrangement codes.
- The key cannot be removed in the return position.

## Illuminated Selector Switch

### ASLW 2 16 22 D R - MAU

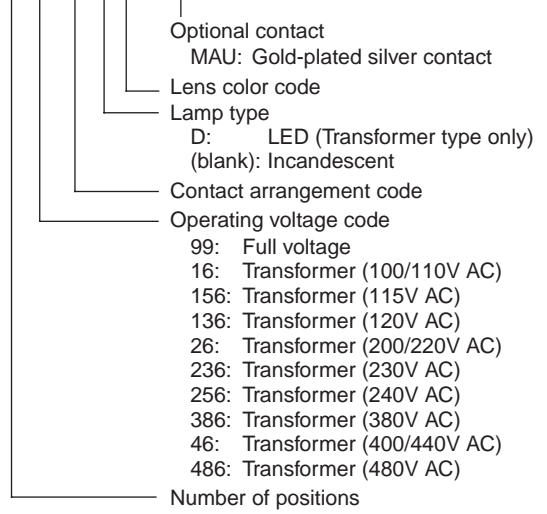







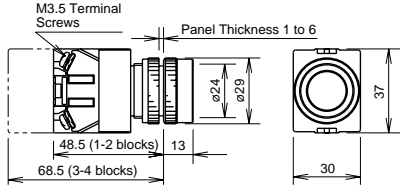

Note:

- Full voltage type is not supplied with a lamp.
- Transformer type contains an LED lamp (LSTD-6<sup>®</sup>) or incandescent lamp (LS-6).
- See pages 27 to 29 for contact arrangement codes.

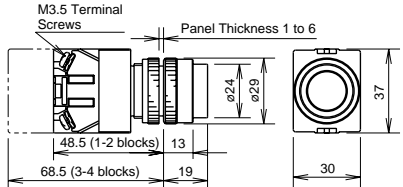

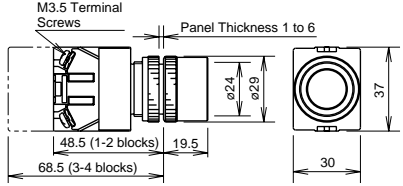

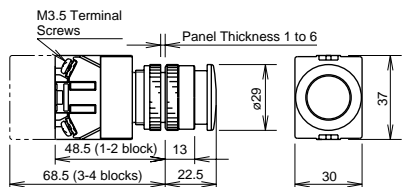



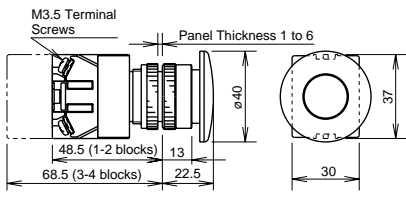

# Ø22 TW Series Pushbuttons

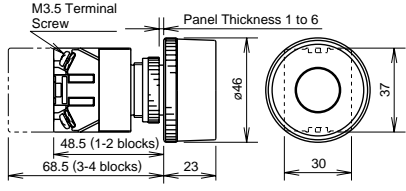
## Flush / Extended / Extended w/Full Shroud / Mushroom Types

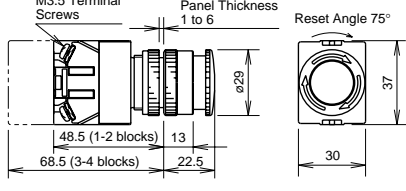
Shape	Operation Type	Contact	Type No.	① Button Color Code	Dimensions (mm)			
Flush ABW1 AOW1    	Momentary	1NO	ABW110①	Specify a button color code in place of ① in the Type No.  B: black G: green R: red S: blue W: white Y: yellow				
		1NC	ABW101①					
		1NO-1NC	ABW111①					
		2NO	ABW120①					
		2NC	ABW102①					
		2NO-2NC	ABW122①					
	Maintained	1NO	AOW110①					
		1NC	AOW101①					
		1NO-1NC	AOW111①					
		2NO	AOW120①					
		2NC	AOW102①					
		2NO-2NC	AOW122①					
		Extended ABW2 AOW2    	Momentary			1NO	ABW210①	
						1NC	ABW201①	
1NO-1NC	ABW211①							
2NO	ABW220①							
2NC	ABW202①							
2NO-2NC	ABW222①							
Maintained	1NO		AOW210①					
	1NC		AOW201①					
	1NO-1NC		AOW211①					
	2NO		AOW220①					
	2NC		AOW202①					
	2NO-2NC		AOW222①					
Extended with Full Shroud ABFW2 AOFW2    	Momentary	1NO	ABFW210①					
		1NC	ABFW201①					
		1NO-1NC	ABFW211①					
		2NO	ABFW220①					
		2NC	ABFW202①					
		2NO-2NC	ABFW222①					
	Maintained	1NO	AOFW210①					
		1NC	AOFW201①					
		1NO-1NC	AOFW211①					
		2NO	AOFW220①					
		2NC	AOFW202①					
		2NO-2NC	AOFW222①					
Ø29mm Mushroom ABW3 AOW3    	Momentary	1NO	ABW310①					
		1NC	ABW301①					
		1NO-1NC	ABW311①					
		2NO	ABW320①					
		2NC	ABW302①					
		2NO-2NC	ABW322①					
	Maintained	1NO	AOW310①					
		1NC	AOW301①					
		1NO-1NC	AOW311①					
		2NO	AOW320①					
		2NC	AOW302①					
		2NO-2NC	AOW322①					

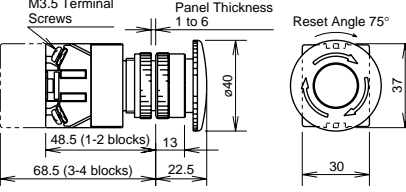
- Specify a button color code in place of ① in the Type No.
- Round bezel and shroud (metal): Mat aluminum color
- Pushbuttons with one or three contact blocks contain a dummy block.
- Other contact arrangements and gold-plated silver contacts are also available. See page 6.

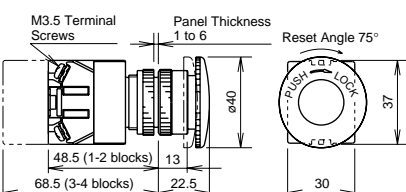
Mushroom / Pushlock Turn Reset / Push Turn Lock / Pushlock Key Reset Types

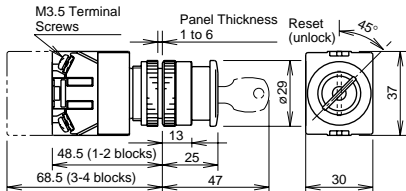





Shape	Operation Type	Contact	Type No.	① Button Color Code	Dimensions (mm)
ø40mm Mushroom ABW4 AOW4 	Momentary	1NO	ABW410①	Specify a button color code in place of ① in the Type No.  B: black G: green R: red S: blue W: white Y: yellow	
		1NC	ABW401①		
		1NO-1NC	ABW411①		
		2NO	ABW420①		
		2NC	ABW402①		
	Maintained	1NO	AOW410①		
		1NC	AOW401①		
		1NO-1NC	AOW411①		
		2NO	AOW420①		
		2NC	AOW402①		
ø40mm Mushroom w/Full Shroud ABGW4 	Momentary	1NO	ABGW410①	Specify a button color code in place of ① in the Type No.  B: black G: green R: red S: blue W: white Y: yellow	
		1NC	ABGW401①		
		1NO-1NC	ABGW411①		
		2NO	ABGW420①		
		2NC	ABGW402①		
		2NO-2NC	ABGW422①		
ø29mm Pushlock Turn Reset AVW3 (Note) 		1NO	AVW310①	R: red Y: yellow	
		1NC	AVW301①		
		1NO-1NC	AVW311①		
		2NO	AVW320①		
		2NC	AVW302①		
		2NO-2NC	AVW322①		
ø40mm Pushlock Turn Reset AVW4 (Note) 		1NO	AVW410①	R: red Y: yellow	
		1NC	AVW401①		
		1NO-1NC	AVW411①		
		2NO	AVW420①		
		2NC	AVW402①		
		2NO-2NC	AVW422①		
ø40mm Push Turn Lock AJW4 		1NO	AJW410①	B: black G: green R: red Y: yellow	
		1NC	AJW401①		
		1NO-1NC	AJW411①		
		2NO	AJW420①		
		2NC	AJW402①		
		2NO-2NC	AJW422①		
ø29mm Pushlock Key Reset AXW3 (Note) 		1NO	AXW310R	Red only	
		1NC	AXW301R		
		1NO-1NC	AXW311R		
		2NO	AXW320R		
		2NC	AXW302R		
		2NO-2NC	AXW322R		

- Specify a button color code in place of ① in the Type No.
- Round bezel (metal): Mat aluminum color
- Pushbuttons with one or three contact blocks contain a dummy block.
- Other contact arrangements and gold-plated silver contacts are also available. See page 6.

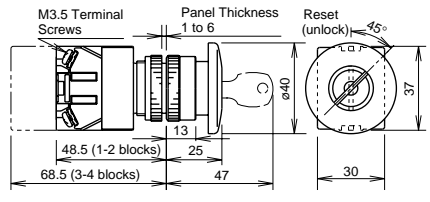
Note: AVW3, AVW4, and AXW3 pushbuttons cannot be used as emergency stop switches. When emergency stop switches are required, use XW or HW series pushbuttons (ISO 13850 and IEC 60947-5-5 compliant).

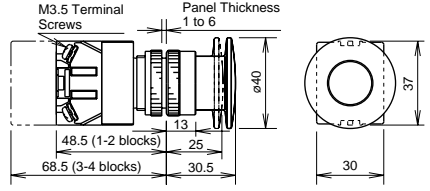
# ø22 TW Series Pushbuttons

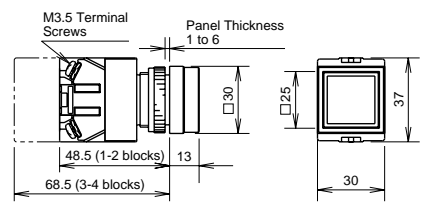
## Pushlock Key Reset / Push-Pull / Square Flush / Square Extended

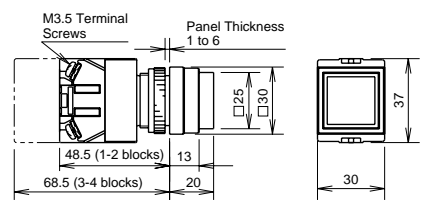
Shape	Operation Type	Contact	Type No.	① Button Color Code	Dimensions (mm)	
ø40mm Mushroom Push Lock Key Reset AXW4 		1NO	AXW410R	Red only		
		1NC	AXW401R			
		1NO-1NC	AXW411R			
		2NO	AXW420R			
		2NC	AXW402R			
		2NO-2NC	AXW422R			
ø40mm Mushroom Push-Pull AYW4 		1NO	AYW410①			
		1NC	AYW401①			
		1NO-1NC	AYW411①			
		2NO	AYW420①			
		2NC	AYW402①			
Square Flush ABQW1 AOQW1 	Momentary	1NO	ABQW110①	B: black G: green R: red S: blue W: white Y: yellow		
			1NC			ABQW101①
			1NO-1NC			ABQW111①
			2NO			ABQW120①
			2NC			ABQW102①
			2NO-2NC			ABQW122①
	Maintained	1NO	AOQW110①			
		1NC	AOQW101①			
		1NO-1NC	AOQW111①			
		2NO	AOQW120①			
		2NC	AOQW102①			
		2NO-2NC	AOQW122①			
Square Extended ABQW2 AOQW2 	Momentary	1NO	ABQW210①			
			1NC			ABQW201①
			1NO-1NC			ABQW211①
			2NO			ABQW220①
			2NC			ABQW202①
			2NO-2NC			ABQW222①
	Maintained	1NO	AOQW210①			
		1NC	AOQW201①			
		1NO-1NC	AOQW211①			
		2NO	AOQW220①			
		2NC	AOQW202①			
		2NO-2NC	AOQW222①			







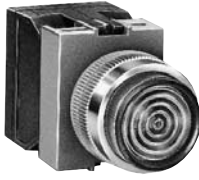

- Specify a button color code in place of ① in the Type No.
- Round bezel (metal): Mat aluminum color
- Square bezel (plastic): Black
- Pushbuttons with one or three contact blocks contain a dummy block.
- Other contact arrangements and gold-plated silver contacts are also available. See page 6.

### • Contact Statuses of Push-Pull Switch

Contact	ø40mm Mushroom Push-Pull Switch	
	Push	Pull
1NO	○—○	○—○
1NC	●—●	●—●
1NO-1NC	○—○ ●—●	○—○ ●—●
2NO	○—○ ○—○	○—○ ○—○
2NC	●—● ●—●	●—● ●—●

- Note: Push-pull switch can have a maximum of two contact blocks.

**Round Flush / Dome / Square Flush Types**

Shape	Lamp	Input Type	Type No.	② Lens/LED Color Code	③ Operating Voltage Code
Round Flush APW1  	Without Lamp	Full Voltage	APW199②	A: amber G: green PW: pure white R: red S: blue W: white Y: yellow	Specify an operating voltage code in place of ③ in the Type No.  16: 100/110V AC 116: 115 AC 126: 120V AC 26: 200/220V AC 236: 230V AC 246: 240V AC 386: 380V AC 46: 400/440V AC 486: 480V AC
	LED	Transformer	APW1③D②	A: amber G: green PW: pure white R: red S: blue W: white Y: yellow	
		DC-DC Converter*	APW11DD②		
Incandescent	Transformer	APW1③②	A: amber G: green R: red S: blue W: white		
Round Flush (Marking) APW1B  	Without Lamp	Full Voltage	APW1B99②	A: amber G: green PW: pure white R: red S: blue W: white Y: yellow	
	LED	Transformer	APW1B③D②	A: amber G: green PW: pure white R: red S: blue W: white Y: yellow	
		DC-DC Converter*	APW1B16DD②		
Incandescent	Transformer	APW1B③②	A: amber G: green R: red S: blue W: white		
Dome APW2  	Without Lamp	Full Voltage	APW299②	A: amber G: green PW: pure white R: red S: blue W: white Y: yellow	
	LED	Transformer	APW2③D②	A: amber G: green PW: pure white R: red S: blue W: white Y: yellow	
		DC-DC Converter*	APW216DD②		
Incandescent	Transformer	APW2③②	A: amber G: green R: red S: blue W: white		
Square Flush (Marking) APQW1B  	Without Lamp	Full Voltage	APQW1B99②	A: amber G: green PW: pure white R: red S: blue W: white Y: yellow	
	LED	Transformer	APQW1B③D②	A: amber G: green PW: pure white R: red S: blue W: white Y: yellow	
		DC-DC Converter*	APQW1B16DD②		
Incandescent	Transformer	APQW1B③②	A: amber G: green R: red S: blue W: white		

- Specify a lens/LED color code in place of ② in the Type No.
  - The white (W) lens of APW1B and APQW1B types is a combination of clear lens and white marking plate.
  - Specify an operating voltage code in place of ③ in the Type No.
  - Full voltage types do not contain a lamp. Order LED or incandescent lamps separately. For lamps, see page 36.
  - LED illuminated transformer and DC-DC converter types contain an LED lamp (LSTD-6②, rated voltage 6V AC/DC).
  - Incandescent illuminated transformer types contain an incandescent lamp (LS-6, rated voltage 6V AC/DC).
  - Round bezel (metal): Mat aluminum color
  - Square bezel (plastic): Black
- \* DC-DC converter types are not approved by UL, CSA, and TÜV, and not CE compliant (operating voltage 90 to 140V DC).

# Ø22 TW Series Pilot Lights

## Dimensions

### • Round Flush APW1 Full Voltage

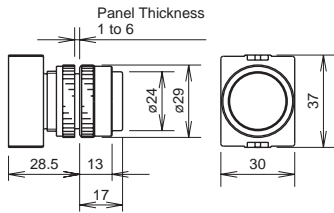

### • Round Flush APW1 Transformer, DC-DC Converter

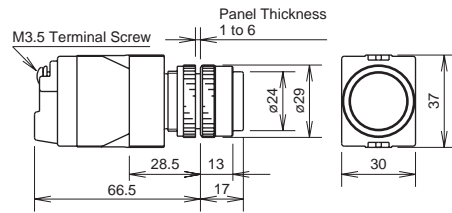

### • Round Flush Marking Type APW1B Full Voltage

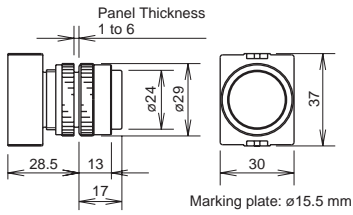

### • Round Flush Marking Type APW1B Transformer, DC-DC Converter

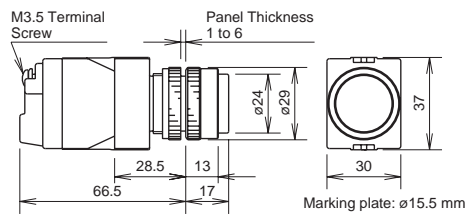

### • Dome APW2 Full Voltage

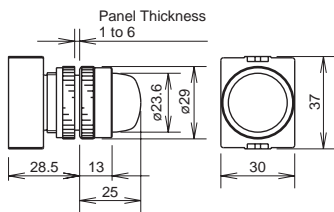

### • Dome APW2 Transformer, DC-DC Converter

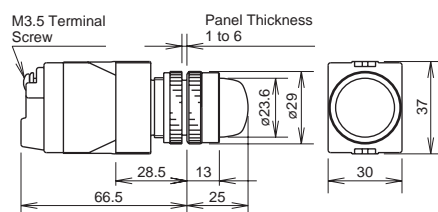

### • Square Flush Marking Type APQW1B Full Voltage

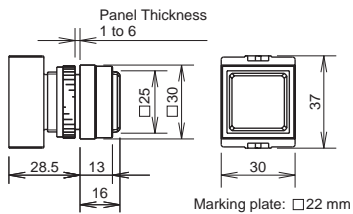

### • Square Flush Marking Type APQW1B Transformer, DC-DC Converter

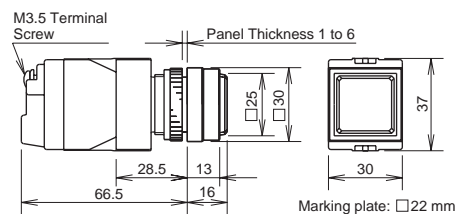



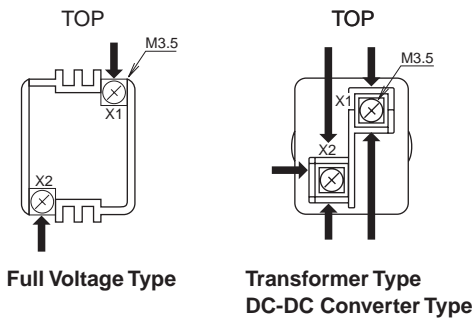

## Terminal Wiring (Bottom View)

• Arrows indicate access directions for wiring.

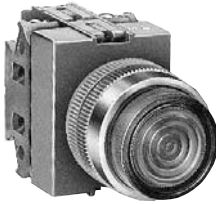

All dimensions in mm.

## Round Extended Illuminated Pushbuttons

Shape	Operation Type	Lamp	Input Type	Contact	Type No.		
Round Extended ALW2 AOLW2       	Momentary	Without Lamp	Full Voltage	1NO-1NC	ALW29911②		
				2NO	ALW29920②		
				2NO-2NC	ALW29922②		
				LED	Transformer	1NO-1NC	ALW2③11D②
						2NO	ALW2③20D②
						2NO-2NC	ALW2③22D②
		DC-DC Converter*	1NO-1NC			ALW21611DD②	
			2NO			ALW21620DD②	
			2NO-2NC			ALW21622DD②	
			Incandescent	Transformer	1NO-1NC	ALW2③11②	
					2NO	ALW2③20②	
					2NO-2NC	ALW2③22②	
	Maintained	Without Lamp			Full Voltage	1NO-1NC	AOLW29911②
						2NO	AOLW29920②
						2NO-2NC	AOLW29922②
			LED	Transformer		1NO-1NC	AOLW2③11D②
						2NO	AOLW2③20D②
						2NO-2NC	AOLW2③22D②
		DC-DC Converter*			1NO-1NC	AOLW21611DD②	
					2NO	AOLW21620DD②	
					2NO-2NC	AOLW21622DD②	
			Incandescent	Transformer	1NO-1NC	AOLW2③11②	
					2NO	AOLW2③20②	
					2NO-2NC	AOLW2③22②	





### • Color Code and Operating Voltage Code

LED Illuminated Type	Incandescent Illuminated Type	③ Operating Voltage Code
② Lens/LED Color Code	② Lens Color Code	
Specify a lens/LED color code in place of ② in the Type No.  A: amber G: green PW: pure white R: red S: blue W: white Y: yellow	Specify a lens color code in place of ② in the Type No.  A: amber G: green R: red S: blue W: white	Specify an operating voltage code in place of ③ in the Type No.  16: Transformer (100/110V AC) 116: Transformer (115V AC) 126: Transformer (120V AC) 26: Transformer (200/220V AC) 236: Transformer (230V AC) 246: Transformer (240V AC) 386: Transformer (380V AC) 46: Transformer (400/440V AC) 486: Transformer (480V AC)

- Full voltage types do not contain a lamp. Order LED or incandescent lamps separately. For lamps, see page 36.
- LED illuminated transformer and DC-DC converter types contain an LED lamp (LSTD-6②, rated voltage 6V AC/DC).
- Incandescent illuminated transformer types contain an incandescent lamp (LS-6, rated voltage 6V AC/DC).
- \* DC-DC converter types are not approved by UL, CSA, and TÜV, and not CE compliant (operating voltage 90 to 140V DC).

# ø22 TW Series Illuminated Pushbuttons

## Round Extended Illuminated Pushbuttons (Marking Type)

Shape	Operation Type	Lamp	Input Type	Contact	Type No.
Round Extended (Marking) ALW2B AOLW2B      	Momentary	Without Lamp	Full Voltage	1NO-1NC	ALW2B9911②
				2NO	ALW2B9920②
				2NO-2NC	ALW2B9922②
		LED	Transformer	1NO-1NC	ALW2B③11D②
				2NO	ALW2B③20D②
				2NO-2NC	ALW2B③22D②
			DC-DC Converter*	1NO-1NC	ALW2B1611DD②
				2NO	ALW2B1620DD②
				2NO-2NC	ALW2B1622DD②
		Incandescent	Transformer	1NO-1NC	ALW2B③11②
				2NO	ALW2B③20②
				2NO-2NC	ALW2B③22②
	Maintained	Without Lamp	Full Voltage	1NO-1NC	AOLW2B9911②
				2NO	AOLW2B9920②
				2NO-2NC	AOLW2B9922②
		LED	Transformer	1NO-1NC	AOLW2B③11D②
				2NO	AOLW2B③20D②
				2NO-2NC	AOLW2B③22D②
			DC-DC Converter*	1NO-1NC	AOLW2B1611DD②
				2NO	AOLW2B1620DD②
				2NO-2NC	AOLW2B1622DD②
		Incandescent	Transformer	1NO-1NC	AOLW2B③11②
				2NO	AOLW2B③20②
				2NO-2NC	AOLW2B③22②

### • Color Code and Operating Voltage Code

LED Illuminated Type	Incandescent Illuminated Type	③ Operating Voltage Code
② Lens/LED Color Code	② Lens Color Code	
Specify a lens/LED color code in place of ② in the Type No.	Specify a lens color code in place of ② in the Type No.	Specify an operating voltage code in place of ③ in the Type No.
A: amber G: green PW: pure white R: red S: blue W: white Y: yellow	A: amber G: green R: red S: blue W: white	16: Transformer (100/110V AC) 116: Transformer (115V AC) 126: Transformer (120V AC) 26: Transformer (200/220V AC) 236: Transformer (230V AC) 246: Transformer (240V AC) 386: Transformer (380V AC) 46: Transformer (400/440V AC) 486: Transformer (480V AC)

- Full voltage types do not contain a lamp. Order LED or incandescent lamps separately. For lamps, see page 36.
  - LED illuminated transformer and DC-DC converter types contain an LED lamp (LSTD-6②, rated voltage 6V AC/DC).
  - Incandescent illuminated transformer types contain an incandescent lamp (LS-6, rated voltage 6V AC/DC).
- \* DC-DC converter types are not approved by UL, CSA, and TÜV, and not CE compliant (operating voltage 90 to 140V DC).

## Round Extended with Full Shroud Illuminated Pushbuttons

Shape	Operation Type	Lamp	Input Type	Contact	Type No.		
	Momentary	Without Lamp	Full Voltage	1NO-1NC	ALFW29911 <sup>②</sup>		
				2NO	ALFW29920 <sup>②</sup>		
				2NO-2NC	ALFW29922 <sup>②</sup>		
				LED	Transformer	1NO-1NC	ALFW2 <sup>③</sup> 11D <sup>②</sup>
						2NO	ALFW2 <sup>③</sup> 20D <sup>②</sup>
						2NO-2NC	ALFW2 <sup>③</sup> 22D <sup>②</sup>
		DC-DC Converter*	1NO-1NC			ALFW21611DD <sup>②</sup>	
			2NO			ALFW21620DD <sup>②</sup>	
			2NO-2NC			ALFW21622DD <sup>②</sup>	
			Incandescent	Transformer	1NO-1NC	ALFW2 <sup>③</sup> 11 <sup>②</sup>	
					2NO	ALFW2 <sup>③</sup> 20 <sup>②</sup>	
					2NO-2NC	ALFW2 <sup>③</sup> 22 <sup>②</sup>	
	Maintained	Without Lamp			Full Voltage	1NO-1NC	AOLFW29911 <sup>②</sup>
						2NO	AOLFW29920 <sup>②</sup>
						2NO-2NC	AOLFW29922 <sup>②</sup>
			LED	Transformer		1NO-1NC	AOLFW2 <sup>③</sup> 11D <sup>②</sup>
						2NO	AOLFW2 <sup>③</sup> 20D <sup>②</sup>
						2NO-2NC	AOLFW2 <sup>③</sup> 22D <sup>②</sup>
		DC-DC Converter*			1NO-1NC	AOLFW21611DD <sup>②</sup>	
					2NO	AOLFW21620DD <sup>②</sup>	
					2NO-2NC	AOLFW21622DD <sup>②</sup>	
			Incandescent	Transformer	1NO-1NC	AOLFW2 <sup>③</sup> 11 <sup>②</sup>	
					2NO	AOLFW2 <sup>③</sup> 20 <sup>②</sup>	
					2NO-2NC	AOLFW2 <sup>③</sup> 22 <sup>②</sup>	





### • Color Code and Operating Voltage Code

LED Illuminated Type	Incandescent Illuminated Type	③ Operating Voltage Code
② Lens/LED Color Code	② Lens Color Code	
Specify a lens/LED color code in place of ② in the Type No.  A: amber G: green PW: pure white R: red S: blue W: white Y: yellow	Specify a lens color code in place of ② in the Type No.  A: amber G: green R: red S: blue W: white	Specify an operating voltage code in place of ③ in the Type No.  16: Transformer (100/110V AC) 116: Transformer (115V AC) 126: Transformer (120V AC) 26: Transformer (200/220V AC) 236: Transformer (230V AC) 246: Transformer (240V AC) 386: Transformer (380V AC) 46: Transformer (400/440V AC) 486: Transformer (480V AC)

- Full voltage types do not contain a lamp. Order LED or incandescent lamps separately. For lamps, see page 36.
- LED illuminated transformer and DC-DC converter types contain an LED lamp (LSTD-6<sup>②</sup>, rated voltage 6V AC/DC).
- Incandescent illuminated transformer types contain an incandescent lamp (LS-6, rated voltage 6V AC/DC).
- \* DC-DC converter types are not approved by UL, CSA, and TÜV, and not CE compliant (operating voltage 90 to 140V DC).

# ø22 TW Series Illuminated Pushbuttons

## Round Extended with Full Shroud Illuminated Pushbuttons (Marking Type)





Shape	Operation Type	Lamp	Input Type	Contact	Type No.
Round Extended (Marking) With Full Shroud ALFW2B AOLFW2B      	Momentary	Without Lamp	Full Voltage	1NO-1NC	ALFW2B9911②
				2NO	ALFW2B9920②
				2NO-2NC	ALFW2B9922②
		LED	Transformer	1NO-1NC	ALFW2B③11D②
				2NO	ALFW2B③20D②
				2NO-2NC	ALFW2B③22D②
			DC-DC Converter*	1NO-1NC	ALFW2B1611DD②
				2NO	ALFW2B1620DD②
				2NO-2NC	ALFW2B1622DD②
		Incandescent	Transformer	1NO-1NC	ALFW2B③11②
				2NO	ALFW2B③20②
				2NO-2NC	ALFW2B③22②
	Maintained	Without Lamp	Full Voltage	1NO-1NC	AOLFW2B9911②
				2NO	AOLFW2B9920②
				2NO-2NC	AOLFW2B9922②
		LED	Transformer	1NO-1NC	AOLFW2B③11D②
				2NO	AOLFW2B③20D②
				2NO-2NC	AOLFW2B③22D②
			DC-DC Converter*	1NO-1NC	AOLFW2B1611DD②
				2NO	AOLFW2B1620DD②
				2NO-2NC	AOLFW2B1622DD②
		Incandescent	Transformer	1NO-1NC	AOLFW2B③11②
				2NO	AOLFW2B③20②
				2NO-2NC	AOLFW2B③22②

### • Color Code and Operating Voltage Code

LED Illuminated Type	Incandescent Illuminated Type	③ Operating Voltage Code
② Lens/LED Color Code	② Lens Color Code	
Specify a lens/LED color code in place of ② in the Type No.	Specify a lens color code in place of ② in the Type No.	Specify an operating voltage code in place of ③ in the Type No.
A: amber G: green PW: pure white R: red S: blue W: white Y: yellow	A: amber G: green R: red S: blue W: white	16: Transformer (100/110V AC) 116: Transformer (115V AC) 126: Transformer (120V AC) 26: Transformer (200/220V AC) 236: Transformer (230V AC) 246: Transformer (240V AC) 386: Transformer (380V AC) 46: Transformer (400/440V AC) 486: Transformer (480V AC)

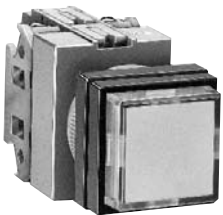
- Full voltage types do not contain a lamp. Order LED or incandescent lamps separately. For lamps, see page 36.
  - LED illuminated transformer and DC-DC converter types contain an LED lamp (LSTD-6②, rated voltage 6V AC/DC).
  - Incandescent illuminated transformer types contain an incandescent lamp (LS-6, rated voltage 6V AC/DC).
- \* DC-DC converter types are not approved by UL, CSA, and TÜV, and not CE compliant (operating voltage 90 to 140V DC).

## Square Extended Illuminated Pushbuttons (Marking Type)

Shape	Operation Type	Lamp	Input Type	Contact	Type No.
Square Extended (Marking) ALQW2B AOLQW2B       	Momentary	Without Lamp	Full Voltage	1NO-1NC	ALQW2B9911 <sup>②</sup>
				2NO	ALQW2B9920 <sup>②</sup>
				2NO-2NC	ALQW2B9922 <sup>②</sup>
		LED	Transformer	1NO-1NC	ALQW2B <sup>③</sup> 11D <sup>②</sup>
				2NO	ALQW2B <sup>③</sup> 20D <sup>②</sup>
				2NO-2NC	ALQW2B <sup>③</sup> 22D <sup>②</sup>
			DC-DC Converter*	1NO-1NC	ALQW2B1611DD <sup>②</sup>
				2NO	ALQW2B1620DD <sup>②</sup>
				2NO-2NC	ALQW2B1622DD <sup>②</sup>
		Incandescent	Transformer	1NO-1NC	ALQW2B <sup>③</sup> 11 <sup>②</sup>
				2NO	ALQW2B <sup>③</sup> 20 <sup>②</sup>
				2NO-2NC	ALQW2B <sup>③</sup> 22 <sup>②</sup>
	Maintained	Without Lamp	Full Voltage	1NO-1NC	AOLQW2B9911 <sup>②</sup>
				2NO	AOLQW2B9920 <sup>②</sup>
				2NO-2NC	AOLQW2B9922 <sup>②</sup>
		LED	Transformer	1NO-1NC	AOLQW2B <sup>③</sup> 11D <sup>②</sup>
				2NO	AOLQW2B <sup>③</sup> 20D <sup>②</sup>
				2NO-2NC	AOLQW2B <sup>③</sup> 22D <sup>②</sup>
			DC-DC Converter*	1NO-1NC	AOLQW2B1611DD <sup>②</sup>
				2NO	AOLQW2B1620DD <sup>②</sup>
				2NO-2NC	AOLQW2B1622DD <sup>②</sup>
		Incandescent	Transformer	1NO-1NC	AOLQW2B <sup>③</sup> 11 <sup>②</sup>
				2NO	AOLQW2B <sup>③</sup> 20 <sup>②</sup>
				2NO-2NC	AOLQW2B <sup>③</sup> 22 <sup>②</sup>

### • Color Code and Operating Voltage Code

LED Illuminated Type	Incandescent Illuminated Type	<sup>③</sup> Operating Voltage Code
<sup>②</sup> Lens/LED Color Code	<sup>②</sup> Lens Color Code	
Specify a lens/LED color code in place of <sup>②</sup> in the Type No.  A: amber G: green PW: pure white R: red S: blue W: white Y: yellow	Specify a lens color code in place of <sup>②</sup> in the Type No.  A: amber G: green R: red S: blue W: white	Specify an operating voltage code in place of <sup>③</sup> in the Type No.  16: Transformer (100/110V AC) 116: Transformer (115V AC) 126: Transformer (120V AC) 26: Transformer (200/220V AC) 236: Transformer (230V AC) 246: Transformer (240V AC) 386: Transformer (380V AC) 46: Transformer (400/440V AC) 486: Transformer (480V AC)

- Full voltage types do not contain a lamp. Order LED or incandescent lamps separately. For lamps, see page 36.
- LED illuminated transformer and DC-DC converter types contain an LED lamp (LSTD-6<sup>②</sup>, rated voltage 6V AC/DC).
- Incandescent illuminated transformer types contain an incandescent lamp (LS-6, rated voltage 6V AC/DC).
- \* DC-DC converter types are not approved by UL, CSA, and TÜV, and not CE compliant (operating voltage 90 to 140V DC).

# ø22 TW Series Illuminated Pushbuttons

## Mushroom (ø29) Illuminated Pushbuttons

Shape	Operation Type	Lamp	Input Type	Contact	Type No.			
ø29 Mushroom ALW3 AOLW3  	Momentary	Without Lamp	Full Voltage	1NO-1NC	ALW39911②			
		Incandescent	Transformer		ALW3③11②			
	Maintained	Without Lamp	Full Voltage		AOLW39911②			
		Incandescent	Transformer		AOLW3③11②			
ø29 Mushroom (Marking Type) ALW3B AOLW3B  	Momentary	Without Lamp	Full Voltage		ALW3B9911②			
		Incandescent	Transformer		ALW3B③11②			
	Maintained	Without Lamp	Full Voltage		AOLW3B9911②			
		Incandescent	Transformer		AOLW3B③11②			
ø29 Mushroom Pushlock Turn Reset AVLW3  	Without Lamp	Full Voltage	Full Voltage	1NO-1NC	AVLW39911R			
				2NO	AVLW39920R			
				2NO-2NC	AVLW39922R			
				1NO-1NC	AVLW3③11DR			
				2NO	AVLW3③20DR			
				2NO-2NC	AVLW3③22DR			
	LED	Transformer	Full Voltage	1NO-1NC	AVLW3③11R			
				2NO	AVLW3③20R			
				2NO-2NC	AVLW3③22R			
				Incandescent	Transformer	Full Voltage	1NO-1NC	AVLW3B9911R
							1NC	AVLW3B9920R
							1NO-1NC	AVLW3B9922R
1NO-1NC	AVLW3B③11DR							
2NO	AVLW3B③20DR							
2NO-2NC	AVLW3B③22DR							
ø29 Mushroom Pushlock Turn Reset (Marking Type) AVLW3B  	Without Lamp	Full Voltage	Full Voltage	1NO	AVLW3B9911R			
				1NC	AVLW3B9920R			
				1NO-1NC	AVLW3B9922R			
				1NO-1NC	AVLW3B③11DR			
				2NO	AVLW3B③20DR			
				2NO-2NC	AVLW3B③22DR			
LED	Transformer	Full Voltage	1NO-1NC	AVLW3B③11R				
			2NO	AVLW3B③20R				
			2NO-2NC	AVLW3B③22R				
			Incandescent	Transformer	Full Voltage	1NO-1NC	AVLW3B③11R	
						2NO	AVLW3B③20R	
						2NO-2NC	AVLW3B③22R	

### • Color Code and Operating Voltage Code

Incandescent Illuminated Type	③ Operating Voltage Code
② Lens Color Code	
Specify a lens color code in place of ② in the Type No.	Specify an operating voltage code in place of ③ in the Type No.
A: amber G: green R: red S: blue W: white	16: Transformer (100/110V AC) 116: Transformer (115V AC) 126: Transformer (120V AC) 26: Transformer (200/220V AC) 236: Transformer (230V AC) 246: Transformer (240V AC) 386: Transformer (380V AC) 46: Transformer (400/440V AC) 486: Transformer (480V AC)

- Full voltage types do not contain a lamp. Order LED or incandescent lamps separately. For lamps, see page 36.
- LED illuminated transformer types contain an LED lamp (LSTD-6②, rated voltage 6V AC/DC).
- Incandescent illuminated transformer types contain an incandescent lamp (LS-6, rated voltage 6V AC/DC).

## Mushroom (ø40 mm) Illuminated Pushbuttons

Shape	Lamp	Input Type	Contact	Type No.
ø40 Mushroom Pushlock Turn Reset AVLW4  	Without Lamp	Full Voltage	1NO-1NC	AVLW49911R
			2NO	AVLW49920R
			2NO-2NC	AVLW49922R
	LED	Transformer	1NO-1NC	AVLW4③11DR
			2NO	AVLW4③20DR
			2NO-2NC	AVLW4③22DR
	Incandescent	Transformer	1NO-1NC	AVLW4③11R
		2NO	AVLW4③20R	
		2NO-2NC	AVLW4③22R	
ø40 Mushroom Pushlock Turn Reset (Marking Type) AVLW4B  	Without Lamp	Full Voltage	1NO	AVLW4B9911R
			1NC	AVLW4B9920R
			1NO-1NC	AVLW4B9922R
	LED	Transformer	1NO-1NC	AVLW4B③11DR
			2NO	AVLW4B③20DR
			2NO-2NC	AVLW4B③22DR
	Incandescent	Transformer	1NO-1NC	AVLW4B③11R
		2NO	AVLW4B③20R	
		2NO-2NC	AVLW4B③22R	
ø40 Mushroom Push Pull AYLW4 (2-position maintained)  	Without Lamp	Full Voltage	1NO-1NC	AYLW49911②
			2NO	AYLW49920②
	Incandescent	Transformer	1NO-1NC	AYLW4③11②
			2NO	AYLW4③20②
ø40 Mushroom Push Pull (Marking Type) AYLW4B (2-position maintained)  	Without Lamp	Full Voltage	1NO	AYLW4B9911②
			1NC	AYLW4B9920②
			1NO-1NC	AYLW4B9922②
	Incandescent	Transformer	1NO-1NC	AYLW4B③11②
			2NO	AYLW4B③20②

### • Color Code and Operating Voltage Code

Incandescent Illuminated Type	③ Operating Voltage Code
② Lens Color Code	
Specify a lens color code in place of ② in the Type No. A: amber G: green R: red S: blue W: white (AYLW4 only)	Specify an operating voltage code in place of ③ in the Type No. 16: Transformer (100/110V AC) 116: Transformer (115V AC) 126: Transformer (120V AC) 26: Transformer (200/220V AC) 236: Transformer (230V AC) 246: Transformer (240V AC) 386: Transformer (380V AC) 46: Transformer (400/440V AC) 486: Transformer (480V AC)

- Full voltage types do not contain a lamp. Order LED or incandescent lamps separately. For lamps, see page 36.
- LED illuminated transformer type contains an LED lamp (LSTD-6②, rated voltage 6V AC/DC).
- Incandescent illuminated transformer types contain an incandescent lamp (LS-6, rated voltage 6V AC/DC).

### • Contact Statuses of Push-Pull Switch

Contact	ø40mm Mushroom Push-Pull Switch	
	Push	Pull
1NO	○ <sup>+</sup> ○	○ <sup>-</sup> ○
1NC	● <sub>1</sub> ●	● <sub>1</sub> ●
1NO-1NC	○ <sup>+</sup> ○ ● <sub>1</sub> ●	○ <sup>-</sup> ○ ● <sub>1</sub> ●
2NO	○ <sup>+</sup> ○ ○ <sup>+</sup> ○	○ <sup>-</sup> ○ ○ <sup>-</sup> ○
2NC	● <sub>1</sub> ● ● <sub>1</sub> ●	● <sub>1</sub> ● ● <sub>1</sub> ●

Note: Push-pull switch can have a maximum of two contact blocks.

# Ø22 TW Series Illuminated Pushbuttons

## Dimensions (Operator)

### Round Extended (non-marking/markings) ALW2 / ALW2B / AOLW2 / AOLW2B

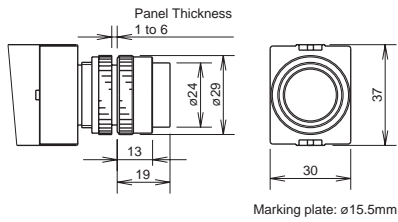

### Round Extended with Full Shroud (non-marking/markings) ALFW2 / ALFW2B / AOLFW2 / AOLFW2B

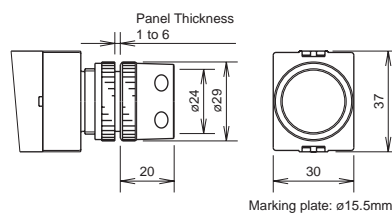

### Square Extended (markings) ALQW2B / AOLQW2B

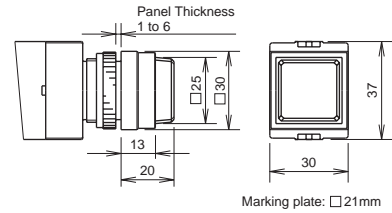

### Ø29 Mushroom (non-marking/markings) ALW3 / ALW3B / AOLW3 / AOLW3B

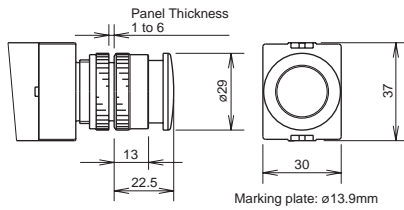

### Ø29 Mushroom Pushlock Turn Reset (non-marking/markings) AVLW3 / AVLW3B

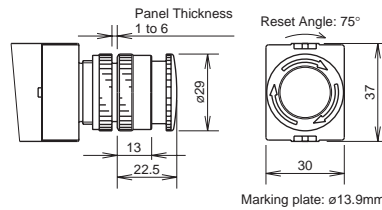

### Ø40 Mushroom Pushlock Turn Reset (non-marking/markings) AVLW4 / AVLW4B

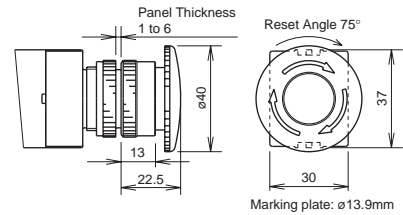

### Ø40 Mushroom Push Pull (non-marking/markings) AYLW4 / AYLW4B

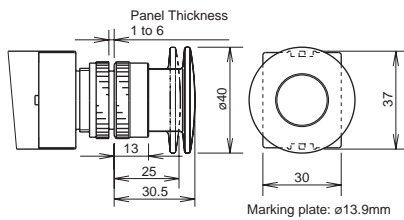

All dimensions in mm.

## Terminal Arrangement (Lamp Terminal) (Bottom View)

• Arrows indicate access directions for wiring.

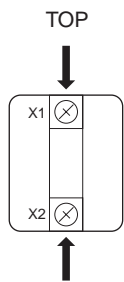

**Full Voltage Type**

When using TW-DA1B Full Voltage Adapter for 2 or 4 contact blocks

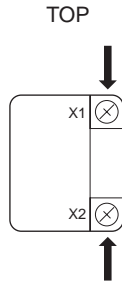

**Full Voltage Type**

When using HW-DA1B Full Voltage Adapter for 1 or 3 contact blocks

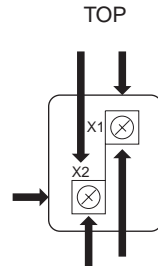

**Transformer Type  
DC-DC Converter Type**

## Dimensions (Behind the Panel)

### • Full Voltage Type

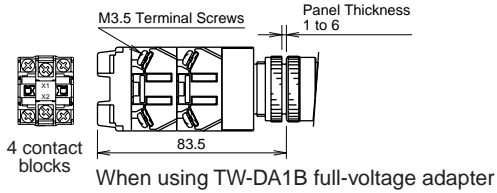
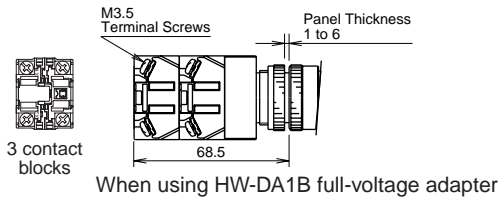
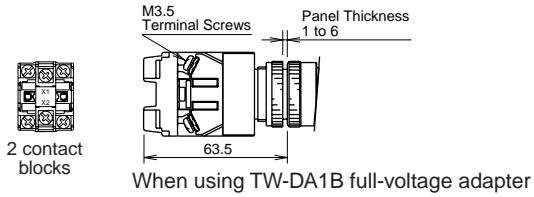
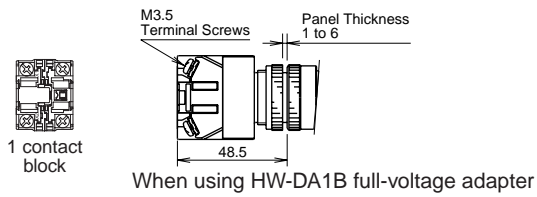

### • Transformer Type • DC-DC Converter Type

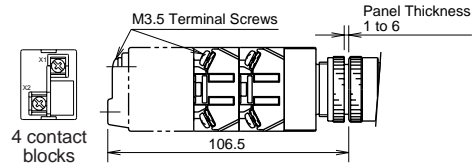
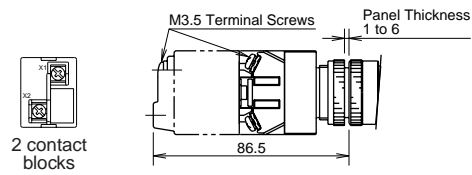

Note: For the push-pull type, a maximum of two contact blocks can be used.

All dimensions in mm.

### • Contact Configuration and Codes

Contact Configuration	Code
1 block	1NO 10
	1NC 01
2 blocks	1NO-1NC 11
	2NO 20
3 blocks	2NO 20
	2NC 02
	2NO-1NC 21
	1NO-2NC 12
4 blocks	3NO 30
	3NC 03
	3NO-1NC 31
	2NO-2NC 22
	1NO-3NC 13
4 blocks	4NO 40
	4NC 04

# ø22 TW Series Selector Switches

## Selector Switches (Knob Operator Type)





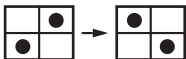



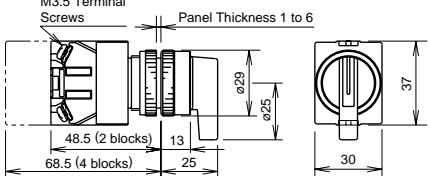

No. of Positions	Shape			ASW							
	Contact Arrangement Chart			CE	UL LISTED	SP	△				
90° 2-position	Contact Code	Contact Block		Operator Position		Maintained	Spring Return from Right	Spring Return from Left			
		Mounting Position	Type	L	R						
	10 (1NO)	1	NO		●	ASW210	ASW2110	ASW2210 *			
		2	Dummy								
	11 (1NO-1NC)	1	NO		●	ASW211	ASW2111	ASW2211 *			
		2	NC	●							
	20 (2NO)	1	NO		●	ASW220	ASW2120	ASW2220 *			
		2	NO		●						
	22 (2NO-2NC)	1	NO		●	ASW222	ASW2122	ASW2222 *			
		2	NC	●							
3		NO		●							
45° 3-position	Contact Code	Contact Block		Operator Position			Maintained	Spring Return from Right	Spring Return from Left	Spring Return Two-way	
		Mounting Position	Type	L	C	R					
	20 (2NO)	1	NO	●			ASW320	ASW3120	ASW3220	ASW3320	
		2	NO			●					
	02 (2NC)	1	NC			●	ASW302	ASW3102	ASW3202	ASW3302	
		2	NC	●							
	22 (2NO-2NC)	1	NO	●			ASW322	ASW3122	ASW3222	ASW3322	
		2	NO			●					
		3	NC			●					
		4	NC	●							
	40 (4NO)	1	NO	●			ASW340	ASW3140	ASW3240	ASW3340	
		2	NO			●					
		3	NO	●							
		4	NO			●					
	04 (4NC)	1	NC			●	ASW304	ASW3104	ASW3204	ASW3304	
		2	NC	●							
3		NC			●						
4		NC	●								
3S ★	1	NO	●			ASW33S-243 ★	—	—	—		
	2	NO			●						
	3	NC			●						
	4	Dummy									
30° 5-position / 45° 4-position	Contact Code	Contact Block		Operator Position					Maintained	Maintained	<p><b>• Contact Block Mounting Position and Contact Arrangement Chart</b></p> <p><b>• For more contact arrangement chart, see pages 27 to 29.</b></p>
		Mounting Position	Type	1	2	3	4	5			
	4S ★	1	NC			●		ASW44S-407 ★	—		
		2	NC		●						
		3	NC			●					
		4	NO				●				
	4S ★	1	NO	●				ASW44S-411 ★	—		
		2	NC		●						
		3	NC			●					
		4	NO				●				
	3S ★	1	NO	●				ASW43S-461 ★	—		
		2	NC		●						
3		NC			●						
4		Dummy									
4S ★	1	NO	●				—	ASW54S-501 ★			
	2	NC		●							
	3	NC			●						
	4	NO				●					

• On the 2-position selector switches marked with \* above, the contact operation is reversed as follows.



- On the contact arrangement marked with ★ in the table above, the rated current (load switching current) is reduced to a half of the rated current of the contact block. The rated insulation voltage and the rated thermal current remain unchanged.
- Selector switches with one or three contact blocks contain a dummy block.
- Knob operator: White indicator on black knob

**Selector Switches (Lever Operator Type)**

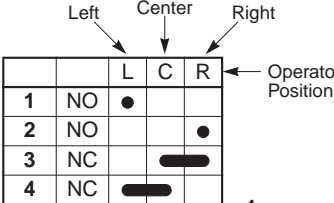
No. of Positions	Shape			ASW*L							
	Contact Arrangement Chart			 							
90° 2-position	Contact Code	Contact Block		Operator Position			Maintained 	Spring Return from Right 	Spring Return from Left 	—	
		Mounting Position	Type	L	R						
	10 (1NO)	1	NO		●						
		2	Dummy								
	11 (1NO-1NC)	1	NO			●					
		2	NC	●							
	20 (2NO)	1	NO			●					
		2	NO				●				
	22 (2NO-2NC)	1	NO			●					
		2	NC	●							
3		NO			●						
4		NC	●								
45° 3-position	Contact Code	Contact Block		Operator Position			Maintained 	Spring Return from Right 	Spring Return from Left 	Spring Return Two-way 	
		Mounting Position	Type	L	C	R					
	20 (2NO)	1	NO	●							
		2	NO			●					
	02 (2NC)	1	NC			●					
		2	NC	●							
	22 (2NO-2NC)	1	NO	●							
		2	NO			●					
		3	NC			●					
		4	NC	●							
	40 (4NO)	1	NO	●							
		2	NO			●					
		3	NO	●							
		4	NO			●					
	04 (4NC)	1	NC			●					
		2	NC	●							
		3	NC			●					
		4	NC	●							
3S ★	1	NO	●								
	2	NO			●						
	3	NC			●						
	4	Dummy									
30° 5-position / 45° 4-position	Contact Code	Contact Block		Operator Position					Maintained 	Maintained 	<b>• Contact Block Mounting Position and Contact Arrangement Chart</b> 
		Mounting Position	Type	1	2	3	4	5			
	4S ★	1	NC			●					
		2	NC			●					
		3	NC				●				
		4	NO					●			
	4S ★	1	NO	●							
		2	NC			●					
		3	NC				●				
		4	NO					●			
	3S ★	1	NO	●							
		2	NC			●					
3		NC				●					
4		Dummy									
4S ★	1	NO	●								
	2	NC			●						
	3	NC				●					
	4	NO					●				

• On the 2-position selector switches marked with \* above, the contact operation is reversed as follows.

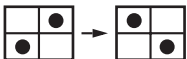

- On the contact arrangement marked with ★ in the table above, the rated current (load switching current) is reduced to a half of the rated current of the contact block. The rated insulation voltage and the rated thermal current remain unchanged.
- Selector switches with one or three contact blocks contain a dummy block.
- Lever operator: White indicator on black lever

# ø22 TW Series Selector Switches

## Key Selector Switches

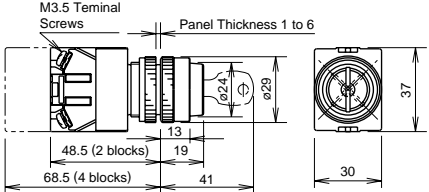
No. of Positions	Shape			ASW* <b>K</b>							
	Contact Arrangement Chart			 							
90° 2-position	Contact Code	Contact Block		Operator Position			Maintained	Spring Return from Right	Spring Return from Left	—	
		Mounting Position	Type	L	R						
	10 (1NO)	1	NO		●		ASW2K10	ASW21K10	ASW22K10 *	—	
		2	Dummy								
	11 (1NO-1NC)	1	NO		●		ASW2K11	ASW21K11	ASW22K11 *		
		2	NC	●							
	20 (2NO)	1	NO		●		ASW2K20	ASW21K20	ASW22K20 *		
		2	NO		●						
	22 (2NO-2NC)	1	NO		●		ASW2K22	ASW21K22	ASW22K22 *		
		2	NC	●							
		3	NO		●						
		4	NC	●							
45° 3-position	Contact Code	Contact Block		Operator Position			Maintained	Spring Return from Right	Spring Return from Left		Spring Return Two-way
		Mounting Position	Type	L	C	R					
	20 (2NO)	1	NO	●			ASW3K20	ASW31K20	ASW32K20	ASW33K20	
		2	NO			●					
	02 (2NC)	1	NC			●	ASW3K02	ASW31K02	ASW32K02	ASW33K02	
		2	NC	●							
	22 (2NO-2NC)	1	NO	●			ASW3K22	ASW31K22	ASW32K22	ASW33K22	
		2	NO			●					
		3	NC			●					
		4	NC	●							
	40 (4NO)	1	NO	●			ASW3K40	ASW31K40	ASW32K40	ASW33K40	
		2	NO			●					
		3	NO	●							
		4	NO			●					
	04 (4NC)	1	NC			●	ASW3K04	ASW31K04	ASW32K04	ASW33K04	
		2	NC	●							
		3	NC			●					
		4	NC	●							
	3S ★	1	NO	●			ASW3K3S-243 ★	—	—	—	
		2	NO			●					
3		NC			●						
4		Dummy									

- On the spring-returned types, the key can be released only from the maintained position. On the maintained types, the key can be released from every position. Key retained positions are also available. See page 7.
- On the 2-position selector switches marked with \* above, the contact operation is reversed as follows.

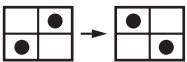

- On the contact arrangement marked with ★ in the table above, the rated current (load switching current) is reduced to a half of the rated current of the contact block. The rated insulation voltage and the rated thermal current remain unchanged.
- Key selector switches with one or three contact blocks contain a dummy block.
- Cylinder cover: Black, Cylinder: Metal

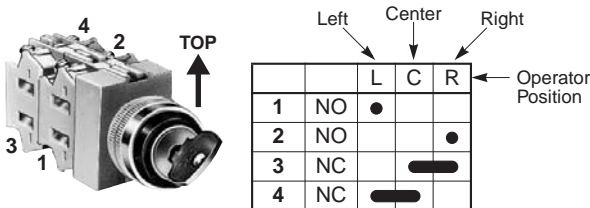

### • Contact Block Mounting Position and Contact Arrangement Chart



- For more contact arrangement chart, see pages 27 to 29.

**Illuminated Selector Switches**

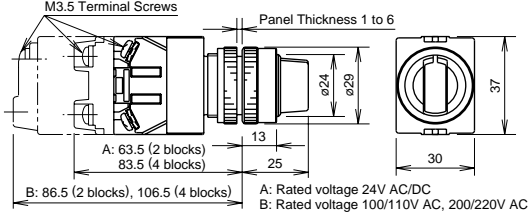
**90° 2-position**

Shape		ASLW							
Contact Arrangement Chart									
Contact Code	Contact Block		Operator Position		Lamp	Input Type	Maintained	Spring Return from Right	Spring Return from Left
	Mounting Position	Type	L	R					
11 (1NO-1NC)	1	NO		●	Without Lamp	Full Voltage	ASLW29911②	ASLW219911②	ASLW229911②
	2	NC	●		LED	Transformer	ASLW2③11D②	ASLW21③11D②	ASLW22③11D②
					Incandescent	Transformer	ASLW2③11②	ASLW21③11②	ASLW22③11②
20 (2NO)	1	NO		●	Without Lamp	Full Voltage	ASLW29920②	ASLW219920②	ASLW229920②
	2	NO		●	LED	Transformer	ASLW2③20D②	ASLW21③20D②	ASLW22③20D②
					Incandescent	Transformer	ASLW2③20②	ASLW21③20②	ASLW22③20②
22 (2NO-2NC)	1	NO		●	Without Lamp	Full Voltage	ASLW29922②	ASLW219922②	ASLW229922②
	2	NC	●		LED	Transformer	ASLW2③22D②	ASLW21③22D②	ASLW22③22D②
	3	NO		●					
	4	NC	●		Incandescent	Transformer	ASLW2③22②	ASLW21③22②	ASLW22③22②

**• Color Code and Operating Voltage Code**

LED Illuminated Type	Incandescent Illuminated Type	③ Operating Voltage Code
② Lens/LED Color Code	② Lens Color Code	
Specify a lens/LED color code in place of ② in the Type No.  A: amber G: green PW: pure white R: red S: blue W: white Y: yellow	Specify a lens color code in place of ② in the Type No.  A: amber G: green R: red S: blue W: white	Specify an operating voltage code in place of ③ in the Type No.  16: Transformer (100/110V AC) 156: Transformer (115V AC) 136: Transformer (120V AC) 26: Transformer (200/220V AC) 236: Transformer (230V AC) 256: Transformer (240V AC) 386: Transformer (380V AC) 46: Transformer (400/440V AC) 486: Transformer (480V AC)

- Full voltage types do not contain a lamp. Order LED or incandescent lamps separately. For lamps, see page 36.
- LED illuminated transformer type contains an LED lamp (LSTD-6②, rated voltage 6V AC/DC).
- Incandescent illuminated transformer types contain an incandescent lamp (LS-6, rated voltage 6V AC/DC).

**• Contact Block Mounting Position and Contact Arrangement Chart**

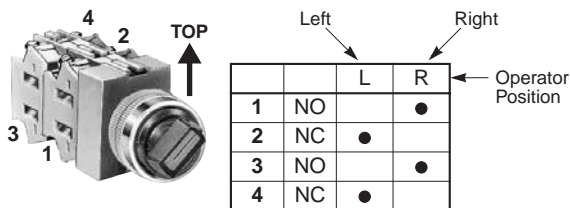

• For more contact arrangement chart, see pages 27 to 29.

# ø22 TW Series Selector Switches

## Illuminated Selector Switches

### 45° 3-position

Contact Code	Contact Block		Operator Position			Lamp Input Type	Maintained	Spring Return from Right	Spring Return from left	Spring Return Two-way
	Mounting Position	Type	L	C	R		L C R	L C R	L C R	L C R
20 (2NO)	1	NO	●			Without Lamp Full Voltage	ASLW39920	ASLW319920	ASLW329920	ASLW339920
	2	NO			●	LED Transformer	ASLW3③20D②	ASLW31③20D②	ASLW32③20D②	ASLW33③20D②
						Incandescent Transformer	ASLW3③20②	ASLW31③20②	ASLW32③20②	ASLW33③20②
02 (2NC)	1	NC		■		Without Lamp Full Voltage	ASLW39902	ASLW319902	ASLW329902	ASLW339902
	2	NC	■			LED Transformer	ASLW3③02D②	ASLW31③02D②	ASLW32③02D②	ASLW33③02D②
						Incandescent Transformer	ASLW3③02②	ASLW31③02②	ASLW32③02②	ASLW33③02②
22 (2NO-2NC)	1	NO	●			Without Lamp Full Voltage	ASLW39922	ASLW319922	ASLW329922	ASLW339922
	2	NO			●	LED Transformer	ASLW3③22D②	ASLW31③22D②	ASLW32③22D②	ASLW33③22D②
	3	NC		■						
	4	NC	■			Incandescent Transformer	ASLW3③22②	ASLW31③22②	ASLW32③22②	ASLW33③22②
40 (4NO)	1	NO	●			Without Lamp Full Voltage	ASLW39940	ASLW319940	ASLW329940	ASLW339940
	2	NO			●	LED Transformer	ASLW3③40D②	ASLW31③40D②	ASLW32③40D②	ASLW33③40D②
	3	NO	●							
	4	NO			●	Incandescent Transformer	ASLW3③40②	ASLW31③40②	ASLW32③40②	ASLW33③40②
04 (4NC)	1	NC		■		Without Lamp Full Voltage	ASLW39904	ASLW319904	ASLW329904	ASLW339904
	2	NC	■			LED Transformer	ASLW3③04D②	ASLW31③04D②	ASLW32③04D②	ASLW33③04D②
	3	NC		■						
	4	NC	■			Incandescent Transformer	ASLW3③04②	ASLW31③04②	ASLW32③04②	ASLW33③04②

### • Color Code and Operating Voltage Code

LED Illuminated Type	Incandescent Illuminated Type	③ Operating Voltage Code
② Lens/LED Color Code	② Lens Color Code	
Specify a lens/LED color code in place of ② in the Type No. A: amber G: green PW: pure white R: red S: blue W: white Y: yellow	Specify a lens color code in place of ② in the Type No. A: amber G: green R: red S: blue W: white	Specify an operating voltage code in place of ③ in the Type No. 16: Transformer (100/110V AC) 156: Transformer (115V AC) 136: Transformer (120V AC) 26: Transformer (200/220V AC) 236: Transformer (230V AC) 256: Transformer (240V AC) 386: Transformer (380V AC) 46: Transformer (400/440V AC) 486: Transformer (480V AC)

- Full voltage types do not contain a lamp. Order LED or incandescent lamps separately. For lamps, see page 36.
- LED illuminated transformer type contains an LED lamp (LSTD-6②, rated voltage 6V AC/DC).
- Incandescent illuminated transformer types contain an incandescent lamp (LS-6, rated voltage 6V AC/DC).

### • Contact Block Mounting Position and Contact Arrangement Chart

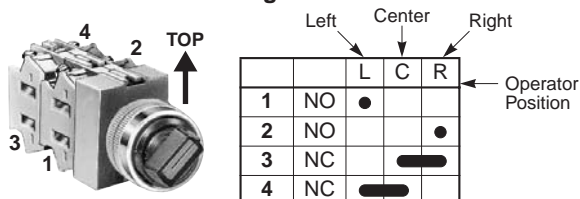

- For more contact arrangement chart, see pages 27 to 29.

# TW Series Selector Switch Contact Arrangement Charts ø22

## 90° 2-position (Maintained / Spring Return)

Positions				Maintained	Spring Return from Right	Spring Return from Left		
Operator Types				Knob, Lever, Key, Illuminated				
Contact Code	Circuit No.	Mounting Position	Type	Operator Positions				
				L	R	L	R	
10 (1NO)	—	1	NO		●	●		
		2	Dummy					
01 (1NC)	—	1	NC	●			●	
		2	Dummy					
11 (1NO-1NC)	—	1	NO		●	●		
		2	NC	●			●	
		103	1	NC	●			●
			2	NO		●	●	
20 (2NO)	—	1	NO		●	●		
		2	NO		●	●		
02 (2NC)	—	1	NC	●			●	
		2	NC	●			●	
22 (2NO-2NC)	—	1	NO		●	●		
		2	NC	●			●	
		3	NO		●	●		
		4	NC	●			●	
	109	1	NO		●	●		
		2	NC	●			●	
		3	NO		●	●		
		4	NO		●	●		
	110	1	NC	●			●	
		2	NO		●	●		
		3	NC	●			●	
		4	NO		●	●		
	111	1	NO		●	●		
		2	NO		●	●		
		3	NC	●			●	
		4	NC	●			●	
117	1	NC	●			●		
	2	NO		●	●			
	3	NO		●	●			
	4	NC	●			●		
31 (3NO-1NC)	107	1	NC	●			●	
		2	NO		●	●		
		3	NO		●	●		
		4	NO		●	●		
40 (4NO)	—	1	NO		●	●		
		2	NO		●	●		
		3	NO		●	●		
		4	NO		●	●		
2R ★	118 ★	1	NO		—————			
		2	NC	—————				
	168 ★	1	NO			—————		
		2	NC	—————				
	119 ★	1	NC	—————				
		2	NO		—————			
	169 ★	1	NC			—————		
		2	NO	—————				
4R ★	120 ★	1	NO		—————			
		2	NC	—————				
		3	NO		—————			
		4	NC	—————				
	170 ★	1	NO			—————		
		2	NC	—————				
		3	NO		—————			
		4	NC	—————				
	121 ★	1	NC	—————				
		2	NO		—————			
		3	NC	—————				
		4	NO		—————			
171 ★	1	NC			—————			
	2	NO	—————					
	3	NC	—————					
	4	NO		—————				

### • Contact Block Mounting Position and Contact Arrangement Chart

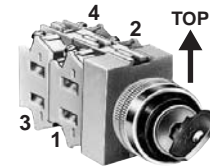

		Left	Right
		L	R
1	NO		●
2	NC	●	
3	NO		●
4	NC	●	

← Operator Position

• On the contact arrangement marked with ★ in the table, the rated current (load switching current) is reduced to a half of the rated current of the contact block. The rated insulation voltage and the rated thermal current remain unchanged.

### Type No. Development

- When circuit number is not required:

**ASW 2 11**

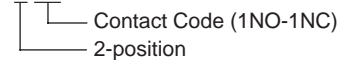

- When circuit number is required:

**ASW 2 11 - 103**

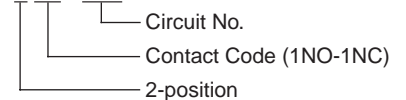

# ø22 TW Series Selector Switch Contact Arrangement Charts

## 45° 3-position (Maintained / Spring Return)

Positions	Maintained	Spring Return from Right	Spring Return from Left	Spring Return Two-way
Operator Types	Knob, Lever, Key, Illuminated			

Contact Code	Circuit No.	Mounting Position	Type	Operator Positions		
11	202	1	NO	•		
		2	NC	—		
	203	1	NC		—	
		2	NO			•
	302	1	NO	•		•
		2	NC	—		
	303	1	NC		•	
		2	NO			•
20	—	1	NO	•		
		2	NO			•
	301	1	NO	•		•
		2	NO			•
02	—	1	NC		—	
		2	NC	—		
	304	1	NC		•	
		2	NC	—		
22 (2NO-2NC)	—	1	NO	•		
		2	NO			•
		3	NC		—	
		4	NC	—		
	210	1	NC		—	
		2	NO			•
		3	NC		—	
		4	NO			•
	308	1	NO	•		
		2	NC	—		
		3	NO	•		•
		4	NC	—		
	309	1	NO	•		•
		2	NC	—		
		3	NC		•	
		4	NO			•
310	1	NC		•		
	2	NO			•	
	3	NC		•		
	4	NO			•	
31 (3NO-1NC)	206	1	NO	•		
		2	NC	—		
	207	3	NO	•		•
		4	NO			•
13	212	1	NO	•		
		2	NC	—		
		3	NC		—	
		4	NC	—		
	313	1	NC		•	
		2	NO			•
		3	NC		•	
		4	NC	—		
40	—	1	NO	•		
		2	NO			•
	305	3	NO	•		•
		4	NO			•
04	—	1	NC		—	
		2	NC	—		
		3	NC		—	
		4	NC	—		
	314	1	NC		•	
		2	NC	—		
		3	NC		•	
		4	NC	—		

### • Contact Block Mounting Position and Contact Arrangement Chart

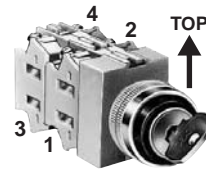

		Left	Center	Right	
		L	C	R	← Operator Position
1	NO	•			
2	NO			•	
3	NC		—		
4	NC	—			

### Type No. Development

- When circuit number is not required:

**ASW 3 22**

— Contact Code (2NO-2NC)  
— 3-position

- When circuit number is required:

**ASW 3 22 - 210**

— Circuit No.  
— Contact Code (2NO-2NC)  
— 3-position

# TW Series Selector Switch Contact Arrangement Charts ø22

## 45° 3-position (Maintained)

Positions				Maintained		
Operator Types				Knob, Lever, Key, Illuminated		
Contact Code	Circuit No.	Mounting Position	Type	Operator Positions		
				L	C	R
2S ★	1361 ★	1	NO	●		
		2	NC		●	
3S ★	243 ★	1	NO	●		
		2	NO			●
		3	NC		●	
		4	Dummy			
4S ★	233 ★	1	NO	●		
		2	NC		■	
		3	NO	●		●
		4	NO			●
	234 ★	1	NO	●		
		2	NC		■	
		3	NC		●	
		4	NC		■	
	235 ★	1	NC			■
		2	NO			●
		3	NC		●	
		4	NO			●
237 ★	1	NO	●			
	2	NO			●	
	3	NC		●		
	4	NO			●	
240 ★	1	NC			■	
	2	NC		■		
	3	NC		●		
	4	NO			●	

## 45° 3-position (Maintained)

Positions				Maintained		
Operator Types				Knob, Lever, Illuminated		
Contact Code	Circuit No.	Mounting Position	Type	Operator Positions		
				L	C	R
4S★	1336 ★	1	NO	●		
		2	NO			●
		3	NC		●	
		4	NC		●	
	1337 ★	1	NC		●	
		2	NO			●
		3	NC		■	
		4	NC		●	
	1352 ★	1	NO	●		
		2	NC		●	
		3	NC		■	
		4	NO	●		●
1355 ★	1	NO	●			
	2	NC		●		
	3	NO	●			
	4	NC		●		
1359 ★	1	NC			■	
	2	NC		●		
	3	NC		■		
	4	NC		●		

## 45° 4-position (Maintained)

Positions				Maintained			
Operator Types				Knob, Lever			
Contact Code	Circuit No.	Mounting Position	Type	Operator Positions			
				1	2	3	4
3S ★	461 ★	1	NO	●			
		2	NC		●		
		3	NC			●	
		4	Dummy				
4S ★	405 ★	1	NC			■	
		2	NC		●		
		3	NC			●	
		4	NC		■		
	407 ★	1	NC			■	
		2	NC		●		
		3	NC			●	
		4	NO				●
	409 ★	1	NO	●			
		2	NC		●		
		3	NC			●	
		4	NC		■		
411 ★	1	NO	●				
	2	NC		●			
	3	NC			●		
	4	NO				●	

## 30° 5-position (Maintained)

Positions				Maintained				
Operator Types				Knob, Lever				
Contact Code	Circuit No.	Mounting Position	Type	Operator Positions				
				1	2	3	4	5
4S ★	501 ★	1	NO	●				
		2	NC		●			
		3	NC				●	
		4	NO					●

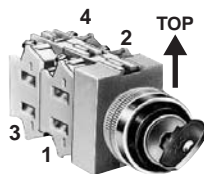









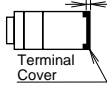

		Left	Center	Right	
		L	C	R	← Operator Position
1	NO	●			
2	NC		■		
3	NO	●		●	
4	NO			●	

• On the contact arrangement marked with ★ in the table, the rated current (load switching current) is reduced to a half of the rated current of the contact block. The rated insulation voltage and the rated thermal current remain unchanged.

## ø22 TW Series Accessories and Replacement Parts

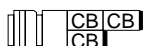
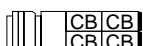
### Accessories

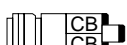
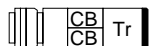
Terminal Cover		HW-VL2	HW-VL3	HW-VL4	HW-VL5	HW-VL6	APS-PVL	Use of terminal covers increases the depth by the dimensions below. 
Control Unit		 39.8H × 14.1W	 37.8H × 26W	 39.8H × 8.7W	 39.1H × 15.5W	 40H × 14.8W	 36H × 29.4W	
• Pilot light APW APQW	Full Voltage						X	+6mm
	Transformer DC-DC Converter		X					+3mm
				X				
• Pushbutton ABW AOW AVW ABQW ABFW AJW AOQW AOFW AXW ABGW AYW	1 contact block 	X						+3.5mm
	2 contact blocks 	X 2 pieces						
	3 contact blocks 	X 2 pieces						
	4 contact blocks 	X 2 pieces						
	• Selector switch ASW							
• Illuminated pushbutton ALW AOLW ALFW AOLFW ALQW AOLQW AVLW AYLW	Full Voltage, 1 or 3 contact blocks 	X 2 pieces						+3.5mm
	Full Voltage, 2 or 4 contact blocks 			X For contact blocks 2 pieces	X For full voltage adapter			+3mm
	• Illuminated selector switch ASLW 	Transformer DC-DC Converter		X				



#### • Ordering Terminal Covers

Terminal covers are ordered separately.

When ordering terminal covers, specify the Type No. and required quantity.

## Nameplates

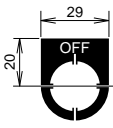
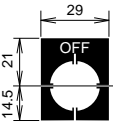
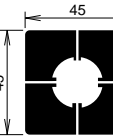
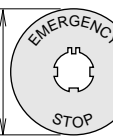
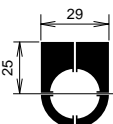
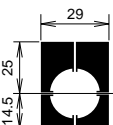
### NWA, NWAQ, NWAQ, NWAQ, NWAQ, and NWAQ

Dimensions (mm)	Legend	Material	Type No.	Ordering Type No.	Package Quantity	Description
	Blank	Aluminium 0.8 mm thick	NWA-0	NWA-0	1	Black
	With Legend			NWA-*	NWA-0PN10	
					NWA-*	1
				NWA-*PN10	10	
	Blank	Aluminium 0.8 mm thick	NWAQ-0	NWAQ-0	1	Black
	With Legend			NWAQ-*	NWAQ-0PN10	
					NWAQ-*	1
				NWAQ-*PN10	10	
	Blank	Aluminium 0.8 mm thick	NWAQ-0	NWAQ-0	1	Black
					NWAQ-0PN10	
	Blank	Aluminium 0.8 mm thick	NWAQ-0	NWAQ-0	1	Yellow
	EMERGENCY STOP			NWAQ-27	NWAQ-27	
					NWAQ-27PN10	10
	Blank	Aluminium 0.8 mm thick	NWAQ-0	NWAQ-0	1	Black
					NWAQ-0PN10	
	Blank	Aluminium 0.8 mm thick	NWAQ-0	NWAQ-0	1	Black
					NWAQ-0PN10	
	Blank	Plastic	NWAQ-0	NWAQ-0	1	Yellow
	EMERGENCY STOP			NWAQ-27	NWAQ-27	











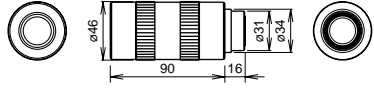

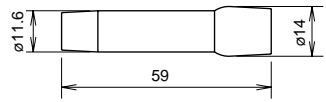

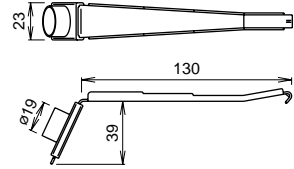
• Specify a legend code in place of \* in the Ordering Type No.

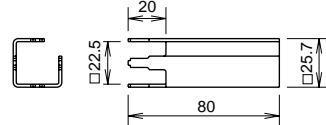

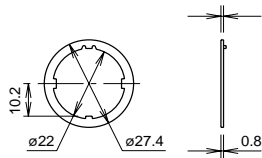

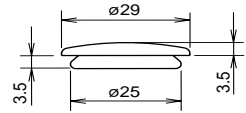

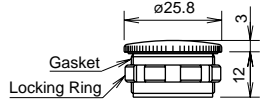

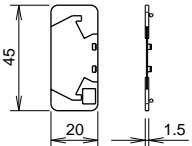
#### Legends

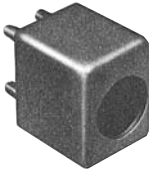
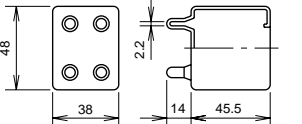
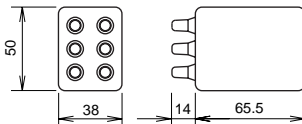
Code	Legend
0	(blank)
1	ON
2	OFF
3	START
4	STOP
31	OFF-ON
35	HAND-AUTO
53	HAND-OFF-AUTO

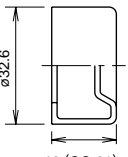
# ø22 TW Series Accessories and Replacement Parts

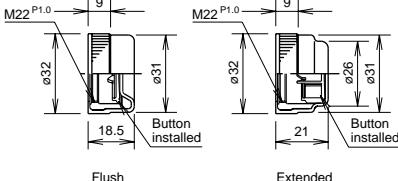
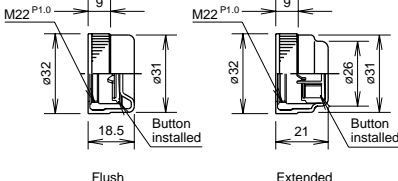
## Accessories

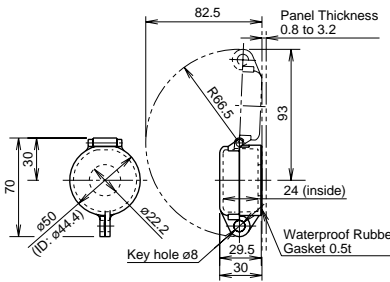
Shape	Material	Type No.	Ordering Type No.	Package Quantity	Dimensions
	Rubber	OR-14	OR-14	1	<ul style="list-style-type: none"> <li>Used to tighten the locking ring when installing the TW control unit onto a panel.</li> </ul>  <p>For ø22/ø25mm units <span style="float: right;">For ø22mm units (close mounting)</span></p>
	Rubber	OR-55	OR-55	1	<ul style="list-style-type: none"> <li>Used to install and remove LED/incandescent lamps.</li> </ul> 
	Metal/Rubber	TW-KC1	TW-KC1	1	<ul style="list-style-type: none"> <li>Used to remove contact blocks, transformers, lenses and adapters. Can also be used to determine panel thickness adjustment.</li> </ul> 
	Metal	TW-KQ2	TW-KQ2	1	<ul style="list-style-type: none"> <li>Used to tighten the locking nuts inside of the square bezel. This tool can be inserted into the OR-14 locking ring wrench.</li> </ul> 
	Metal	OGL-31	OGL-31PN10	10	<ul style="list-style-type: none"> <li>Used to prevent the operator from rotating. Generally used when using no nameplates on selector switches.</li> </ul> 
	Rubber (black)	OB-31	OB-31PN05	5	<ul style="list-style-type: none"> <li>Used to plug unused ø22.2mm mounting holes.</li> </ul> 
	Diecast Metal (locking ring: plastic)	LW9Z-BM	LW9Z-BM	1	<ul style="list-style-type: none"> <li>Used to plug unused ø22.2mm mounting holes.</li> <li>Tightening torque: 1.2 N·m</li> <li>Degree of protection: IP66 (without the 3.2mm recess in the mounting hole)</li> </ul> 
	Plastic	HW-VL1	HW-VL1PN10	10	<ul style="list-style-type: none"> <li>Used to prevent contact between adjacent lead wires when units are mounted closely. Barriers should be always used in close mounting.</li> </ul> 

<b>Accessories</b>							
Shape	Material	Type No.	Ordering Type No.	Package Quantity	Description		
	For 1 layer of contact blocks (2 contact blocks)	Rubber (nitril)	OCW-99	OCW-99	1	<ul style="list-style-type: none"> <li>• Oiltight rubber boot used for pushbuttons and selector switches.</li> <li>• Temperature range: -5 to +60°C</li> <li>• Black</li> </ul> 	
	For 2 layers of contact blocks (4 contact blocks)		OCW-299	OCW-299	1		
	For flush pushbuttons (ABW1/AOW1)	Rubber (EPDM)	OC-31	OC-31	1	<ul style="list-style-type: none"> <li>• Used to cover and protect pushbuttons where units are subject to water splash. Not suitable for outdoor use or where the units are subject to oil splash.</li> </ul> 	
	For extended pushbuttons (ABW2/AOW2)		OC-32	OC-32	1		
	For flush pushbuttons (ABW1/AOW1)	Rubber (nitril)	OCW-10①	OCW-10①	1	<ul style="list-style-type: none"> <li>• Metallic bezels covered with rubber boot to enhance waterproof and oiltight characteristics.</li> <li>• Button is installed in the cover. Remove the button from the pushbutton before using the button cover.</li> <li>• ①: B (black), G (green), R (red), Y (yellow)</li> </ul> 	
	For extended pushbuttons (ABW2/AOW2)		OCW-11①	OCW-11①	1		
		Polyarylate (gasket: nitril rubber)	HW9Z-KL1	HW9Z-KL1	1	<ul style="list-style-type: none"> <li>• Used to protect momentary and maintained pushbuttons, illuminated pushbuttons, knobs selector switches, and key selector switches.</li> </ul> 	
	Non-marking Type	Plastic	ALW4L-②	ALW4L-②	1	<ul style="list-style-type: none"> <li>• Applicable unit: ALW3, AOLW3</li> </ul>	②: G (green), R (red) S (blue)
			ALW4LD-②	ALW4LD-②	1		②: A (amber), W (white)
	Marking Type		ALW4BL-②	ALW4BL-②	1	<ul style="list-style-type: none"> <li>• Applicable unit: ALW3B, AOLW3B</li> </ul>	②: G (green), R (red), S (blue), W (white)
			ALW4BLD-②	ALW4BLD-②	1	<ul style="list-style-type: none"> <li>• Marking plate is included</li> </ul>	②: A (amber)

Note: Specify a button color code or lens color code in place of ① or ② in the Ordering Type No.

# ø22 TW Series Accessories and Replacement Parts







## Accessories

Shape	Material	Type No.	Ordering Type No.	Package Quantity	Dimensions	
<b>Plastic Bezel</b> 	Plastic	① Flush	AW-RP1B	AW-RP1BPN05	5	
		② Extended	AW-FP1B	AW-FP1B	1	
		③ Extended (for illuminated pushbuttons)	AW-FP2B	AW-FP2B	1	
		④ Square round (for round pushbuttons)	AW-H1B	AW-H1B	1	
		⑤ Square	AW-Q1B	AW-Q1B	1	
<b>Aluminium Bezel</b> 	Aluminium	① Flush	AW-R1	AW-R1PN05	5	
		② Extended	AW-R1B	AW-R1B	1	
		③ Extended (for illuminated pushbuttons)	AW-F1	AW-F1	1	
		④ Mushroom	AW-G4	AW-G4	1	
<b>Selector Operator</b> 	Plastic	① Knob	ASWHHY-②	ASWHHY-②PN02	2	<ul style="list-style-type: none"> <li>Specify a color code in place of ②. B (black), G (green), R (red)</li> <li>Black only</li> <li>Specify a color code in place of ②. B (black), G (green), R (red), S (blue), W (white), Y (yellow)</li> <li>Specify a color code in place of ②. A (amber), W (white), Y (yellow)</li> <li>Specify a color code in place of ②. G (green), R (red), S (blue)</li> </ul>
		② Lever	ASWHHL-②	ASWHHL-②PN02	2	
		③ Round	ASWHHM-B	ASWHHM-BPN02	2	
		④ Color Insert	TW-HC1②	TW-HC1②PN05	5	
		⑤ Illuminated selector	ASLWDDY-②	ASLWDDY-②	1	
<b>Metal Protector</b> 	Metal	OLW-C	OLW-C	1	<ul style="list-style-type: none"> <li>Used to protect flush pushbuttons from inadvertent operation.</li> </ul>	

## Maintenance Parts

Shape	Specification	Type No.	Ordering Type No.	Package Quantity	Color	
					Housing	Push Rod
	1NO contact	HW-C10	HW-C10	1	Blue	Green
	1NC contact	HW-C01	HW-C01	1	Purple red	Red
	EM contact (early make)	HW-C10R	HW-C10R	1	Blue	Black
	LB contact (late break)	HW-C01R	HW-C01R	1	Purple red	White
		TW-DB	TW-DBPN10	10	<ul style="list-style-type: none"> <li>Used for non-illuminated units with 1NO or 1NC contact blocks.</li> <li>Black</li> </ul>	
		TW-DA1B	TW-DA1BPN02	2	<ul style="list-style-type: none"> <li>Adapter with M3.5 screws used for illuminated pushbutton or illuminated selector switch. Snaps on to the back of the contact block.</li> <li>Used with 2 or 4 contact blocks.</li> <li>Black</li> </ul>	
		HW-DA1B	HW-DA1BPN02	2	<ul style="list-style-type: none"> <li>Adapter with M3.5 screws used for illuminated pushbuttons or illuminated selector switch.</li> <li>Used with 1 or 3 contact blocks.</li> <li>Black</li> </ul>	

## Maintenance Parts

Shape	Material	Type No.	Ordering Type No.	Package Quantity	Color Code
	AS	APW1L-②	APW1L-②PN05	5	G (green), R (red), S (blue)
		APW1LD-②	APW1LD-②PN05	5	A (amber), W (white), Y (yellow)
	AS, Marking type	APW11L-②	APW11L-②PN05	5	C (clear), G (green), R (red), S (blue)
		APW11LD-②	APW11LD-②PN05	5	A (amber), Y (yellow)
	AS	APW2L-②	APW2L-②PN05	5	G (green), R (red), S (blue)
		APW2LD-②	APW2LD-②PN05	5	A (amber), W (white), Y (yellow)
	AS, Marking type	APQW11L-②	APQW11L-②PN05	5	C (clear), G (green), R (red), S (blue)
		APQW11LD-②	APQW11LD-②PN05	5	A (amber), Y (yellow)
	AS	ALW2L-②	ALW2L-②PN05	5	G (green), R (red), S (blue)
		ALW2LD-②	ALW2LD-②PN05	5	A (amber), W (white), Y (yellow)
	AS, Marking type	ALW21L-②	ALW21L-②PN05	5	C (clear), G (green), R (red), S (blue)
		ALW21LD-②	ALW21LD-②PN05	5	A (amber), Y (yellow)
	AS	ALQW21L-②	ALQW21L-②PN05	5	C (clear), G (green), R (red), S (blue)
		ALQW21LD-②	ALQW21LD-②PN05	5	A (amber), Y (yellow)
	AS	ALW3L-②	ALW3L-②PN02	2	G (green), R (red), S (blue)
		ALW3LD-②	ALW3LD-②PN02	2	A (amber), W (white), Y (yellow)
	AS, Marking type	ALW31L-②	ALW31L-②PN02	2	C (clear), G (green), R (red), S (blue)
		ALW31LD-②	ALW31LD-②PN02	2	A (amber), Y (yellow)
AS, Marking type	AVLW3L-R	AVLW3L-RPN02	2		
AS, Marking type	AVLW31L-R	AVLW31L-RPN02	2		
AS	AVLW4L-R	AVLW4L-RPN02	2		
	Polyacetal	ABW1B-①	ABW1B-①PN05	5	B (black) G (green) R (red) S (blue) W (white) Y (yellow)
		ABW2B-①	ABW2B-①PN05	5	
		ABQW1B-①	ABQW1B-①PN05	5	
		ABQW2B-①	ABQW2B-①PN05	5	
		ABW3B-①	ABW3B-①PN02	2	
		ABW4B-①	ABW4B-①PN02	2	
		AVW3B-①	AVW3B-①PN02	2	R (red), Y (yellow)
		AVW4B-①	AVW4B-①PN02	2	R (red), Y (yellow)
		AYW4B-①	AYW4B-①PN02	2	B (black), G (green), R (red), S (blue), W (white), Y (yellow)
				APW2B	APW2BPN05
APQW1B	APQW1BPN05			5	
	Acrylic	ALW2B	ALW2BPN05	5	• White
		ALQW2B	ALQW2BPN05	5	
		ALW3B	ALW3BPN05	5	
	Acrylic	For APQW	APW00LN	APW00LNPN05	5
		For ALQW	APW00L	APW00LPN05	5



Note: Specify a button color code or lens color code in place of ① or ② in the Ordering Type No.  
Use a clear lens for white or pure white illumination.

## ø22 TW Series Accessories and Replacement Parts





### Maintenance Parts

Shape	Material	Type No.	Ordering Type No.	Package Quantity
 <p>Spare Key</p> <p>For Key Selector Switch For Pushlock Key Reset</p>	Metal	TW-SK-0	TW-SK-0PN02	2

### LED Lamps (LSTD Type)

Operating Voltage	Current Draw		Type No.	Ordering Type No.	Illumination Color Code	Package Quantity	Base
	AC	DC					
 <p>6V AC/DC ±5%</p>	17 mA (A, R, W, Y) 8 mA (G, PW, S)	14 mA (A, R, W, Y) 5.5 mA (G, PW, S)	LSTD-6②	LSTD-6②	Specify a color code in place of ② in the Ordering Type No.  A: amber G: green PW: pure white R: red S: blue W: white Y: yellow	1	BA9S/13
				LSTD-6②PN10		10	
 <p>12V AC/DC ±10%</p>	11 mA	10 mA	LSTD-1②	LSTD-1②	1		
				LSTD-1②PN10	10		
 <p>24V AC/DC ±10%</p>	11 mA	10 mA	LSTD-2②	LSTD-2②	1		
				LSTD-2②PN10	10		

### Incandescent Lamps (LS Type)

Rated Operating Voltage	Lamp Ratings	Type No.	Package Quantity
 <p>6V AC/DC</p>	1W (6.3V)	LS-6	1
 <p>12V AC/DC</p>	1W (18V)	LS-8	
 <p>18V AC/DC</p>	1W (24V)	LS-2	
 <p>24V AC/DC</p>	1W (30V)	LS-3	

### Transformer

Shape	Primary Voltage	Secondary Voltage	Type No.
 <p>Transformer Unit</p>	100/110V AC	5.5V	TW-T16B
	120V AC		TW-T126B
	200/220V AC		TW-T26B
	240V AC		TW-T246B

### Safety Precautions

- Turn off the power to the TW series control units before starting installation, removal, wiring, maintenance, and inspection of the products. Failure to turn power off may cause electrical shocks or fire hazard.
- To avoid a burn on your hand, use the lamp holder tool when replacing lamps.
- For wiring, use wires of a proper size to meet the voltage and current requirements. Tighten the M3.5 terminal screws to a tightening torque of 1.0 to 1.3 N·m. Failure to tighten terminal screws may cause overheat and fire.

- Use HW-C type contact blocks for the TW series. Do not replace with or add conventional TW series contact blocks. Using a different type of contact block may lead to malfunction.

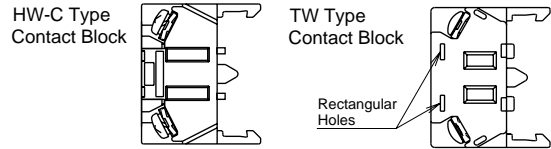

### Instructions

#### Panel Mounting

Panel thickness adjustment ring is used for the TW series. To attach the TW series to the panel, follow the procedures below.

Mounting order	① Panel Thickness Adjustment	② Attaching the Unit to the Panel with the Bezel	③ Attaching the Button, Lens, and Knob					
	 Panel thickness adjustment ring	 Panel, Bezel	 Panel, Lens					
Remarks		Attach the unit with the panel thickness scale facing up.	Installation method					
			<table border="1"> <thead> <tr> <th>Type</th> <th>Method</th> </tr> </thead> <tbody> <tr> <td>Flush/Extended pushbuttons, Square lens, Selector operator</td> <td>Press in</td> </tr> <tr> <td>29mm/40mm mushroom button/lens, Dome lens</td> <td>Screw in</td> </tr> </tbody> </table>	Type	Method	Flush/Extended pushbuttons, Square lens, Selector operator	Press in	29mm/40mm mushroom button/lens, Dome lens
Type	Method							
Flush/Extended pushbuttons, Square lens, Selector operator	Press in							
29mm/40mm mushroom button/lens, Dome lens	Screw in							
Tools	Locking ring wrench		For tightening or removing round bezels.					
	Nut locking wrench		For tightening or removing square bezels.					
	Contact block removal tool	Panel thickness adjustment	For installing or removing waterproof lenses after the bezel is attached.					

#### Adjusting Panel Thickness

The panel thickness ring provides adjustment from 1 to 6 mm in 1-mm increments. Set the panel thickness to line A. Rotate the ring until the desired thickness indication around the periphery is aligned with line A, as shown below.

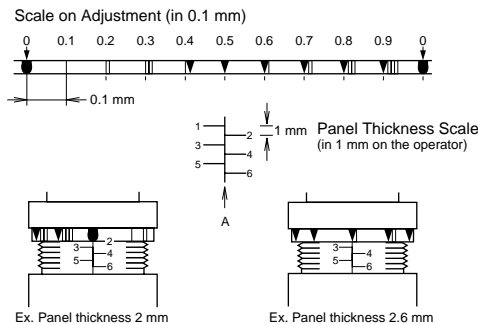

Note: When a nameplate or an anti-rotation ring is used, add 0.8mm to the panel thickness.

Total thickness = Panel thickness + 0.8mm (nameplate or anti-rotation ring thickness)

#### Using the Contact Block Removal Tool to Adjust Panel Thickness

Panel thickness can easily be adjusted to the values shown below by inserting the contact block removal tool between the adjustment ring and base.

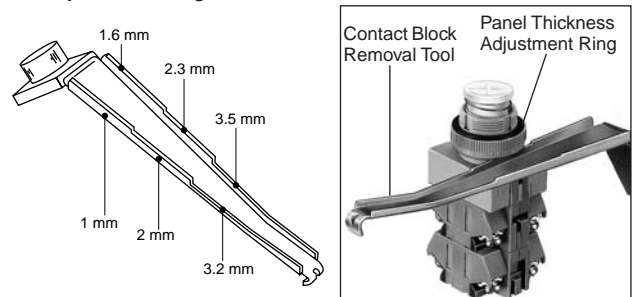

Instructions

Mounting into Panel Cut-out with Bezel

• Insertion into Panel Cut-out

Insert the base into the panel cut-out making sure that the panel thickness scale is facing up.

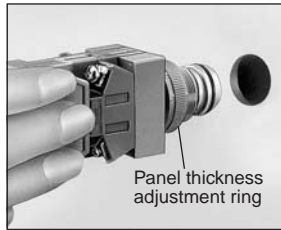

• Round Bezel

All round bezels are screw-in type. Be sure to use the locking ring wrench to tighten the bezel.

Locking Ring Wrench OR-14 (optional)

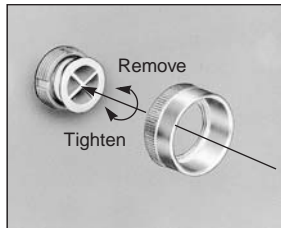
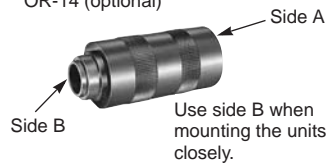

• Recommended tightening torque is 2.0 N-m.

• Square Bezel

1. Insert the base plate from the front.

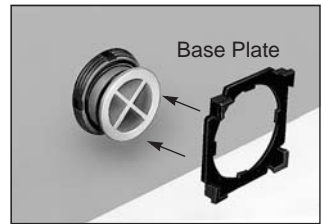

2. Insert the lock nut. For easy installation, use the nut locking wrench.



Nut Locking Wrench TW-KQ2 (optional)



3. Mount the square bezel. The bezel will snap onto the base plate.

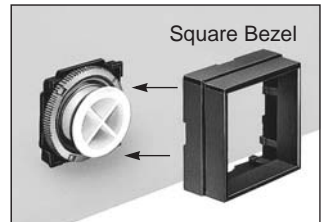

Installing Buttons, Lenses, and Operators

• Lens Structure and Marking Plate

All square lens units are marking types. To engrave on the marking plate, remove the marking plate from the lens.

[Square Pilot Lens]

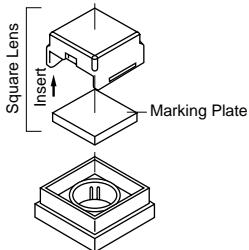

[Square Illuminated Pushbutton]

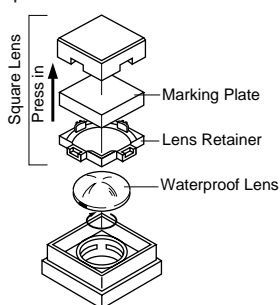

[Round Marking Type]

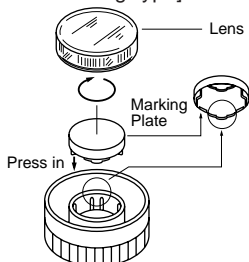

1. Removing the Square Lens  
Insert the screwdriver into the recess of the lens and lightly push out the lens.

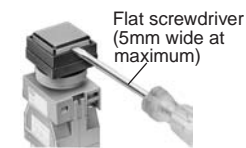

2. Removing the Marking Plate

• Pilot Light  
Insert the screwdriver into the recess of the lens.

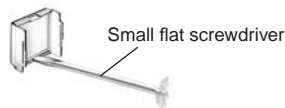

• Illuminated Pushbuttons  
Insert the screwdriver into the hook and lightly push out the lens.

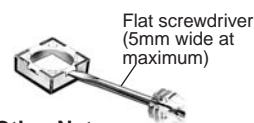

3. Other Notes

The square lens of the illuminated pushbutton cannot be used without waterproof lens. Always use the waterproof lens. Be sure to use the marking plate even when it is not engraved.

• Marking Plate Engraving Area

Round	Mushroom	Square (Pilot Light)	Square (Illuminated Pushbutton)

Note: The depth of the engraving must be within 0.5 mm.

• Installing Round Lens and Waterproof Lens

When installing or removing round lens of pilot lights and illuminated pushbuttons and waterproof lens of square pilot lights and illuminated pushbuttons, press the rubber part of the contact block removal tool onto the lens or waterproof lens for secure tightening and easy removal.

**Instructions**

• **Installation of Selector Operators**

1. The shaft of each selector or illuminated selector switch has a recess to identify in which direction to install the operator. Align the operator with the recess and press in the operator.
2. Press color insert (non-illuminated type) into the operator. The color insert retains the operator.

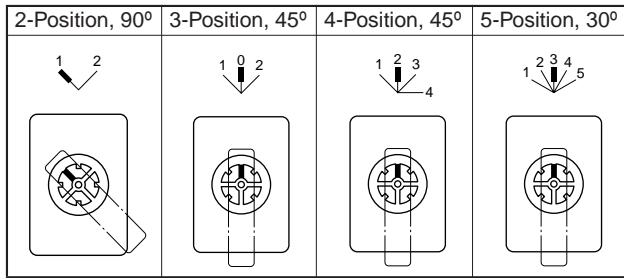
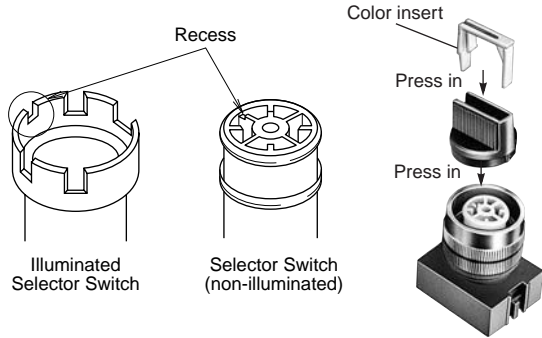

[Example]

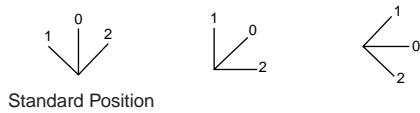

The non-illuminated operators can be installed in positions other than the standard position as shown above.

• **Removing the Operator**

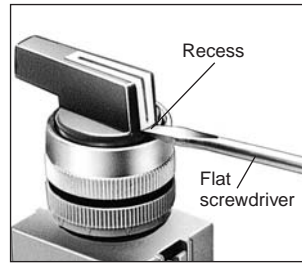

**1. Removing the Color Insert**

Insert a flat screwdriver into the recess of the color insert. Turn the screwdriver to push out the insert from the operator

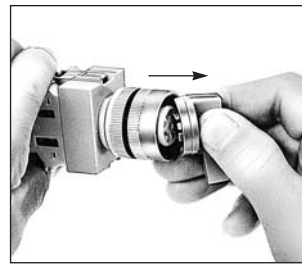

**2. Removing the Operator (Non-illuminated)**

Push the operator sideways as shown in the left photo to remove the operator.

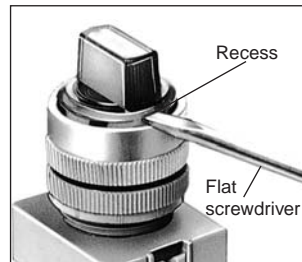

**3. Removing the Operator (Illuminated)**

Insert a flat screwdriver into the recess of the operator and turn the screwdriver to remove the operator.

**Removing Contact Blocks, Transformers and Full Voltage Adapters**

Insert the end of the contact block removal tool into the snap-fit latch of the contact block (or transformer, full-voltage adapter) and pull the tool as shown below.

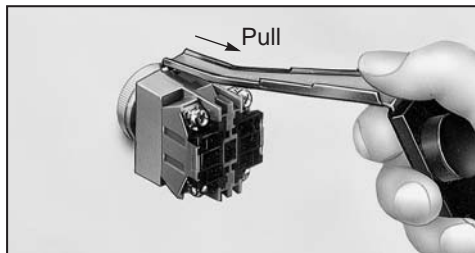

**Collective Mounting**

When mounting the units closely in a horizontal row on 30-mm centers, use optional barriers to prevent interconnection between adjoining terminals. The barriers can be attached simply by pressing them onto the sides of contact blocks.

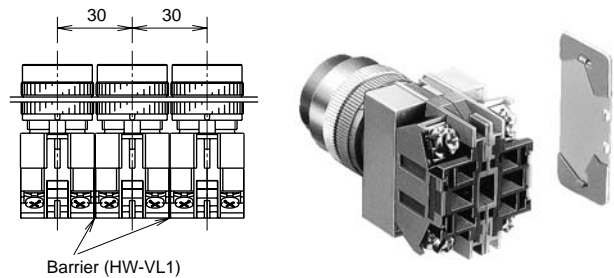

**Tightening Torque for Terminal Screws**

Tighten the M3.5 terminal screws to a torque of 1.0 to 1.3 N·m

## Installation of LED Illuminated Units

- Note the polarity for wiring when connecting to DC-DC converter unit.

Terminal No.	Polarity
X1	Positive
X2	Negative

- Transformer type units are recommended for use in areas subjected to noise.

## Notes on LED Illuminated Units

LED lamps consist of semiconductors. If the applied voltage exceeds the rated voltage, LED elements may deteriorate due to overheat, resulting in significant decrease in luminance, hue change, or failure of lighting. Also, if an extraneous noise, transient voltage, or transient current is applied to the circuit, similar effects may occur. When using LED lamps, observe the following instructions.

### • Rated Voltage

The LED lamps are rated at 6V, 12V, or 24V AC/DC, and can be used within  $\pm 10\%$  the rated voltage of either AC or DC.

### • DC Power

- Switching power supply  
Regulated voltage from switching power supply is best suited. Make sure to use within the rated voltage of the LED lamp.
- Rechargeable battery  
Note that the battery voltage may exceed the rated voltage of the LED lamp while the battery is being charged and immediately after the charging is complete. Be sure to use the LED lamp on a voltage of  $\pm 10\%$  the rated voltage.
- Full-wave rectification  
Since the LED lamp is AC/DC compatible, a diode bridge for rectification is not necessary. If the LED lamp is used on a full-wave rectification current through a diode bridge, the rectifier diodes will reduce the voltage, resulting in lower luminance.
- Single-phase half-wave rectification  
This is not suitable for the power source of LED lamps. Use constant-voltage DC power.

### • Noise

LED elements deteriorate due to extraneous noise, resulting in significant decrease in luminance, hue change, or failure of lighting. When such effects are anticipated, take a protection measure shown below, such as RC elements or a surge absorber.

- Notes for Pure White LED Lamps

- Do not use the pure white LED outdoors, otherwise it will lead to the degradation of brightness and color. Do not remove or apply shock to the cap on the pure white LED lamp, otherwise it may break or damage the cap.
- For the pure white LED, use a white lens. The illumination color will be dull if a different color is used.

### [Protection Example 1] For AC circuit

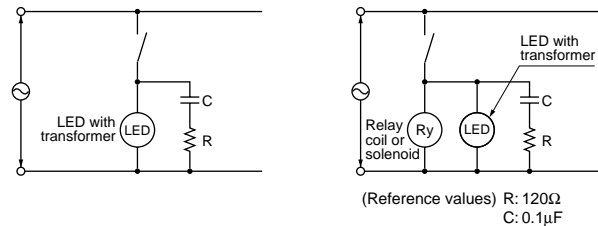

### [Protection Example 2] For DC circuit

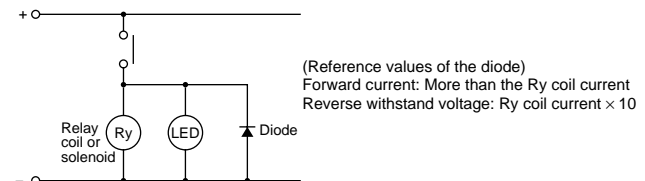

### • Countermeasures against Dim Lighting

- Leakage currents through the transistors or a contact protection circuit may cause the LED lamp to illuminate dimly even when the output is off.
- When the LED lamp is illuminated by a transistor output, take the following measure.

### [Circuit Example]

Connect shunt resistor R in parallel with the LED lamp.

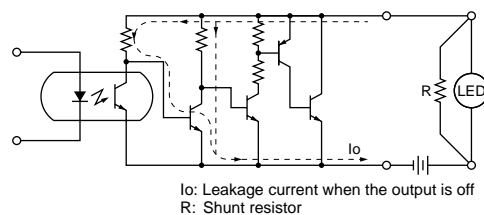

Specifications and other descriptions in this catalog are subject to change without notice.



## IDEC IZUMI CORPORATION

**IDEC CORPORATION (USA)**  
1175 Elko Drive, Sunnyvale, CA 94089-2209, USA  
Tel: +1-408-747-0550, Toll Free: (800) 262-IDEC, Fax: +1-408-744-9055  
E-mail: opencontact@idec.com, www.idec.com

**IDEC CANADA LIMITED**  
Unit 22-151, Brunel Road Mississauga, Ontario, L4Z 1X3, Canada  
Tel: +1-905-890-8561, Toll Free: (888) 317-4332, Fax: +1-905-890-8562

**IDEC ELECTRONICS LIMITED**  
Unit 2, Beechwood, Chineham Business Park, Basingstoke, Hampshire RG24 8WA, UK  
Tel: +44-1256-321000, Fax: +44-1256-327755  
E-mail: idec@uk.idec.com

**IDEC ELEKTROTECHNIK GmbH**  
Wendenstrasse 331, D-20537 Hamburg, Germany  
Tel: +49-40-25 30 54-0, Fax: +49-40-25 30 54-24  
E-mail: service@idec.de, www.idec.de

**IDEC AUSTRALIA PTY. LTD.**  
2/3 Macro Court, Rowville, Victoria 3178, Australia  
Toll Free: 1-800-68-4332, Fax: +61-3-9763-3255  
E-mail: sales@au.idec.com

7-31, Nishi-Miyahara 1-Chome, Yodogawa-ku, Osaka 532-8550, Japan  
Tel: +81-6-6398-2571, Fax: +81-6-6392-9731  
www.idec.com

**IDEC IZUMI ASIA PTE. LTD.**  
No. 31, Tannery Lane #05-01, Dragon Land Building, Singapore 347788  
Tel: +65-6746-1155, Fax: +65-6844-5995  
E-mail: generalinfo@idecasia.com.sg

**IDEC IZUMI (H.K.) CO., LTD.**  
Unit 1505-07, DCH Commercial Centre No. 25, Westlands Road, Quarry Bay, Hong Kong  
Tel: +852-2803-8989, Fax: +852-2565-0171  
E-mail: idec@idechk.com

**IDEC IZUMI (Shanghai) Co., Ltd.**  
Room E, 15F, Majesty Building, No. 138 Pudong Avenue, Shanghai 200120, P.R.C.  
Tel: +86-21-5887-9181, Fax: +86-21-5887-8930  
E-mail: idec@cn.idec.com

**IDEC TAIWAN CORPORATION**  
8F, No. 79, Hsin Tai Wu Road, Sec. 1, Hsi-Chih, Taipei County, Taiwan  
Tel: +886-2-2698-3929, Fax: +886-2-2698-3931  
E-mail: service@idectwn.com.tw